

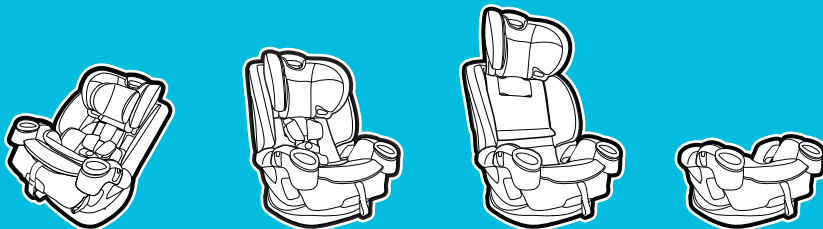

# 4EVER<sup>®</sup> DLX SNUGLOCK<sup>®</sup> GROW<sup>™</sup>

## 4-IN-1 CAR SEAT

**Read This Instruction Manual**



**Do not install or use this child restraint until you read and understand the instructions in this manual.**

**FAILURE TO PROPERLY USE THIS CHILD RESTRAINT INCREASES THE RISK OF SERIOUS INJURY OR DEATH IN A SUDDEN STOP OR CRASH.**

# 1 Important

*Pages 6-27*

**1-A Quick Guide to Your Manual**

**1-B Welcome to the Graco Family**

**1-C Right Mode of Use**

**1-D Before You Begin**

Register This Car Seat

If You Need Help

Certification

Car Seat's Useful Life

Vehicle Seat Protection

Warm Weather Use

**1-E Safety Warnings**

# 2 Features

*Pages 28-35*

## **3 Rear-Facing**

*Pages 36-55*

**3-A Rear-Facing Use**

**3-B Install Rear-Facing with Lower Anchor Attachment**

**3-C Install Rear-Facing with Vehicle Seat Belt**

## **4 Forward-Facing**

*Pages 56-75*

**4-A Forward-Facing Use**

**4-B Install Forward-Facing with LATCH**

**4-C Install Forward-Facing with the Vehicle Seat Belt**

## **5 Securing Child**

*Pages 76-84*

**5-A Securing Child 5-Point Harness**

## **6 Booster**

*Pages 85-113*

**6-A Booster Use**

**6-B Install Highback Booster**

**6-C Install Backless Booster**

**6-D Securing Child Highback Booster**

**6-E Securing Child Backless Booster**

## **7 Moving the Lower Anchor Attachment**

*Pages 114-119*

## **8 Accessories**

*Pages 120-121*

## **9 Additional Information**

*Pages 122-136*

- 9-A How to Uninstall Lower Anchor Connectors and Tether**
- 9-B Choosing Vehicle Seat Location**
- 9-C Unsafe Vehicle Seat Location**
- 9-D Vehicle Seat Belts**
- 9-E Aircraft Installation**

## **10 Care & Cleaning**

*Pages 137-142*

- 10-A Cleaning Rapid Remove Seat Pad**
- 10-B Cleaning the Buckle**
- 10-C Cleaning Harness, Lower Anchor Attachment and Tether**

# 1-A Quick Guide to Your Manual

This car seat is for children:

**Rear-Facing:** 4-40 lb (1.8-18 kg)

**Forward-Facing:** 22-65 lb (10-30 kg)

**Highback Booster:** 40-100 lb (18.1-45 kg)

**Backless Booster:** 40-120 lb (18.1-54 kg)

- Infants who weigh less than 22 lb (10 kg) **MUST be rear-facing**. Review section 1-C for more information.

**Note:** Preterm or low birth weight infants may be at special risk in a vehicle or aircraft. According to the AAP, these infants may suffer breathing issues if improperly reclined in a car seat. When rear-facing, use the corrected age for preemies. Graco advises that you have your physician or hospital staff evaluate your infant and recommend the proper car seat or car bed before you and your infant leave the hospital.

## Install Cup Holders

Cup holders must be installed.

To attach the cup holders, match the right cup holder (find the letter R on the bottom of the cup holder) to the right side of the seat and the left "L" to the left.

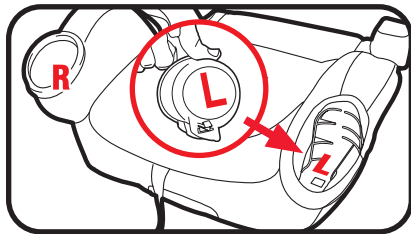

Move the fabric aside and align the tab behind the cup holder with the slot in the seat.



Align the tab on the bottom of the cup holder with the hole in the seat.

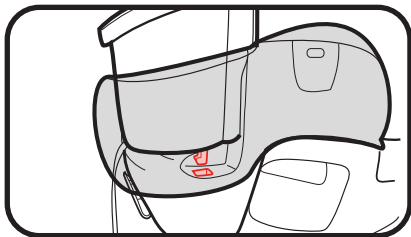
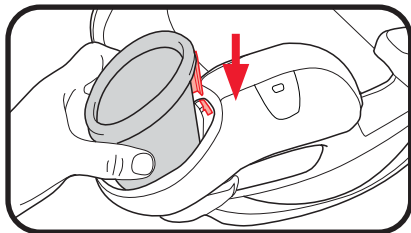

Use both hands to push down hard on the cup holder. **You will hear a “Click” when they are secured in place.**

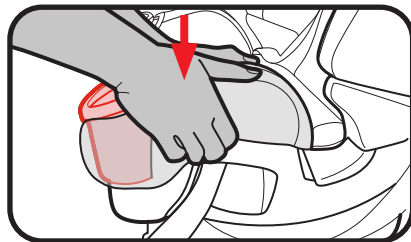

**1** Important

## ***Get to Know Your Car Seat***

Review section 2-A to see all of the features of this car seat.

## ***What Seating Location Should I Use?***

***The best seating location for this car seat is one that:***

- Is recommended by your vehicle owner's manual, and
- Results in a secure installation of this car seat.

Some vehicles have specific requirements for where the car seat can be installed, so be sure to check your vehicle owner's manual for available seating positions, if any. For example, sometimes the center rear seat has a lap belt only vehicle seat belt, which cannot be used when this car seat is in Booster mode.

Review section 9-B, 9-C, 9-D of this manual AND your vehicle owner's manual.

## **! WARNING!**



**NEVER place this child restraint rear-facing in a vehicle seating location that has an active front air bag.**

In the event there is no back seat, review your vehicle owner's manual to see how to use your child restraint.





**According to accident statistics, children are safer when properly restrained in the rear seating positions than in the front seating positions. The center of the back seat can be the safest during a possible side impact.**



**1** Important

### ***Which Installation Method Should I Use?***

This car seat can be installed in your vehicle using either the vehicle seat belt **OR** the lower anchor attachment. Both are equally safe to use. **INSTALL USING ONLY ONE METHOD.**

Graco allows the securing of the car seat with the LATCH system in the booster mode, only if the vehicle manufacturer allows it. The child still **MUST BE SECURED** with the vehicle lap/shoulder seat belt.

**Vehicle Seat Belt:** Review section 9 and your vehicle owner's manual to learn how to install your car seat with the vehicle seat belts.

**LATCH or Lower Anchor Attachment:** The LATCH system or lower anchor attachment allows you to securely attach your safety seat in your car without using the vehicle seat belt and possibly to get a better fit. All 2003 and newer model year vehicles are required to have a LATCH system, although some manufacturers began including LATCH earlier. Some vehicle owner manuals use the term ISOFIX to identify the LATCH system.

## What is LATCH?

LATCH consists of lower anchors and a tether anchor, which are built in to your vehicle, and a lower anchor attachment and a tether that are built in to your car seat. The lower anchor attachment is used **INSTEAD** of the vehicle's seat belt to secure the child seat to the vehicle. The tether is used **IN ADDITION** to the lower anchor attachment **OR** the vehicle's seat belt to secure a forward-facing car seat to the vehicle.

***Review your vehicle owner's manual for exact location and use.***

**Vehicle's Tether Anchor**

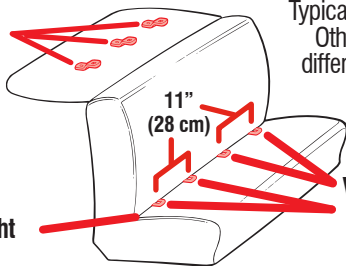

Typical seat in a passenger vehicle.  
Other vehicle types may have different lower anchor and tether anchor locations.

**Vehicle Seat Bight**

**Vehicle's Lower Anchor**



## When Installing Rear-Facing or Forward-Facing

### Lower Anchor Attachment

Lower anchor attachment consists of lower anchors, which are built in to your vehicle, and lower anchor connectors that are built in to your car seat.

Review section 3-B, 4-B of this manual AND your vehicle owner's manual before installing.

**Lower anchor attachment can ONLY be used if the vehicle lower anchor spacing is 11 inches (28 cm) from the center of one lower anchor to the center of the other lower anchor.**

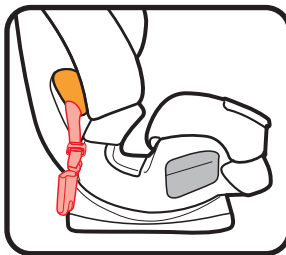
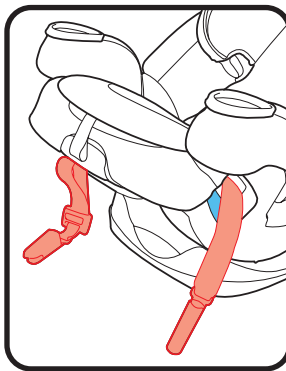
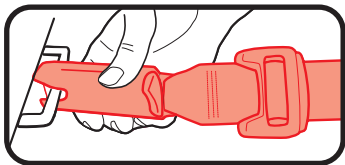

**1 Important**



**1** Important

## ***When Installing Rear-Facing or Forward-Facing (continued)***

### **Vehicle Seat Belt**

There are two types of vehicle seat belts that can be used. Lap/Shoulder Seat Belt or Lap Only Seat Belt.

Review section 3-C, 4-C and 9 of this manual AND your vehicle owner's manual before installing.

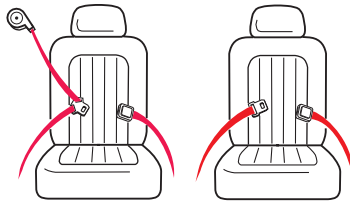

## ***When Installing As a Booster***

### **Vehicle Seat Belt**

Only use the Lap/Shoulder seat belt configuration.

Review section 6-B, 6-C, 6-D, 6-E and 9 of this manual AND your vehicle owner's manual.

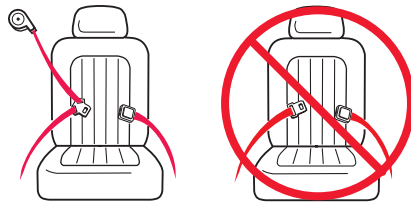

## Does Your Car Seat Fit Your Child Correctly?

To make sure your child is secured properly, review section 3, 4, 5 and 6 to understand all of the actions you need to take to properly adjust the car seat to fit your child.

### For Rear-Facing and Forward-Facing, You Need to Adjust:

#### Harness Height, Rear-Facing

Harness straps at or just below the child's shoulders  
**(A)**. Top of head must be 1" (2.5 cm) below the headrest adjustment lever **(B)**.

Review section 5

#### Harness Height, Forward-Facing

Harness straps at or just above the child's shoulders  
**(C)**. Top of child's ears below top of headrest **(D)**.

Review section 5

#### Buckle Position (E)

The correct slot is the one that is closest to your child without being underneath them.

Review section 5

#### Harness Tightness (F)

If your fingers slide off the harness straps without pinching the straps, it is tight enough.

Review section 5

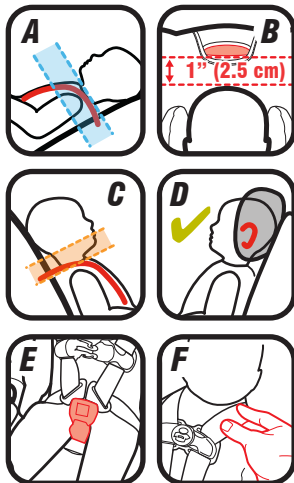

1 Important



**1** Important

## ***For Booster, You Need to Adjust:***

### **Use Lap/Shoulder Belt Only**



### **Position Lap Belt**

Lap belt must go behind armrest and lie low across your child's hips and thighs.

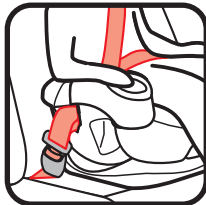
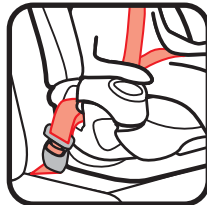

### **Position Shoulder Belt**

Shoulder belt lies across shoulder between neck and edge of shoulder.

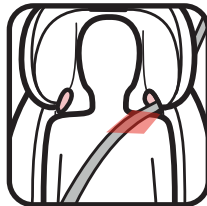

## Did You Do Everything Correctly?

### Rear-Facing

**Car Seat Does Not Move More than 1" (2.5 cm) at the Belt Path (A)**

Review section 3

**Level Indicator's Bubble in the Blue Zone (B)**

Review section 3

**Harness Straps at or Just Below the Child's Shoulders (C)**

Review section 5

**Chest Clip Even With Armpits (D)**

Review section 5

**Cannot Pinch Harness Straps at the Shoulder (E)**

Review section 5

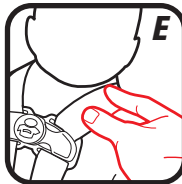
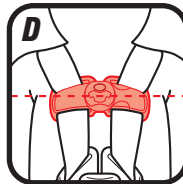
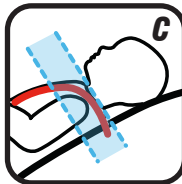
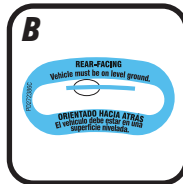
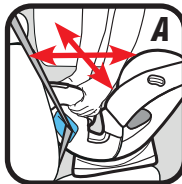

**1 Important**

## Forward-Facing

### Use the tether strap when using forward-facing (A)

When used properly, the tether helps reduce injury in a sudden stop or crash.

Review section 4

### Car Seat Does Not Move More than 1" (2.5 cm) at the Belt Path (B)

Review section 4

### Harness Straps at or Just Above Child's Shoulders (C)

Review section 5

### Chest Clip Even With Armpits (D)

Review section 5

### Cannot Pinch Harness Straps at the Shoulder (E)

Review section 5

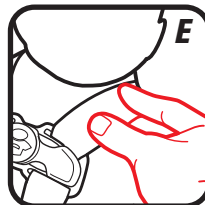
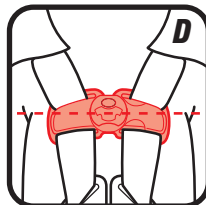
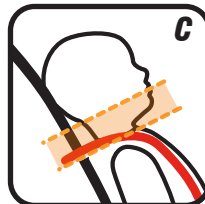
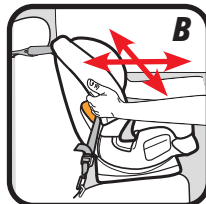
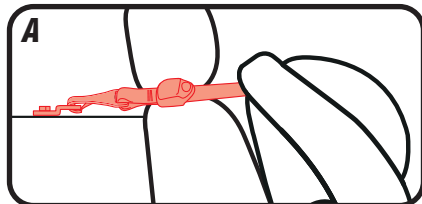



## **Booster**

### **Never Use Lap Belt Only**

Review section 6



### **Lap Belt Behind Armrest and Lies Low Across Hips and Thighs**

Review section 6

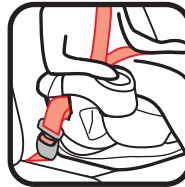
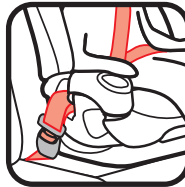

### **Shoulder Belt Lies On the Shoulder, Between the Neck and Edge of Shoulders**

Review section 6



**1 Important**

## 1-B Welcome to the Graco Family!



**1 Important**

Your child's safety depends on you. No car seat can guarantee protection from injury in every situation, but proper use helps reduce the risk of serious injury or death.

Even if this car seat seems easy to figure out on your own, you must follow the detailed instructions in this instruction manual to ensure the steps below are performed correctly.

## 1-C Right Mode of Use

4 lb  
(1.8 kg)

22 lb  
(10 kg)

40 lb  
(18 kg)

65 lb  
(30 kg)

120 lb  
(54 kg)

**Rear-Facing with 5-Point Harness**  
**Must be 49" (125 cm) or less:**  
4-22 lb (1.8-10 kg) less than 1 year old **MUST** be rear-facing.  
22-40 lb (10-18 kg) **SHOULD** be rear-facing.\*

**Forward-Facing with 5-Point Harness**  
**Must be 49" (125 cm) or less:**  
22-40 lb (10-18 kg) can sit upright unassisted **CAN** be forward-facing.  
40-65 lb (18-30 kg) **SHOULD** be forward-facing.\*

**Booster Mode with Vehicle Lap/Shoulder Seat Belt**  
**Must be 43-57" (110.1-145 cm) tall and 4+ years old**  
40-65 lb (18.1-30 kg) **CAN** be in Highback booster mode.  
40-65 lb (18.1-30 kg) **CAN** be in Backless booster mode.  
Over 65 lb (30 kg) **MUST** be in booster mode.\*

\*Check your state laws and the AAP/NHTSA recommendations. Review page 25 more for information.



**1** Important

# 1-D Before You Begin

## *Register This Child Restraint*



1 Important

1

Please fill out the prepaid registration postcard attached to the harness and mail it in today **or register online at [www.gracobaby.com/carseatregistration](http://www.gracobaby.com/carseatregistration)**.

Child restraints could be recalled for safety reasons. You must register this restraint to be reached in a recall. Send your name, address, and the restraint's model number and manufacturing date to:

Graco Children's Products, Inc.

Attn: Customer Service

P.O. Box 169, Elverson, PA 19520-9901

or call 1-800-345-4109

**or register online at**

**[www.gracobaby.com/carseatregistration](http://www.gracobaby.com/carseatregistration)**

For recall information, call the U.S. Government's Vehicle Safety Hotline at 1-888-327-4236 (TTY: 1-800-424-9153), or go to <http://www.NHTSA.gov>.

For future reference or if you change addresses, record the model name, model number, date of manufacture and purchase date of this car seat on the below. You can find this information either on the registration card if you still have it or on the date label located on the bottom of the car seat.

**Model Name** \_\_\_\_\_

**Model Number** \_\_\_\_\_

**Date of Manufacture** \_\_\_\_\_

**Date of Purchase** \_\_\_\_\_

### ***If You Need Help***

In the U.S.A, please contact our Customer Service Department with any questions you may have concerning parts, use, or maintenance. When you contact us, please have your product's model number and date of manufacture ready so that we may help you efficiently. These numbers can be found on a sticker on the bottom of your car seat.

For additional resources or to get your car seat checked by a child passenger safety technician, please visit the following web sites:

[www.nhtsa.gov](http://www.nhtsa.gov) • [www.seatcheck.org](http://www.seatcheck.org) • [www.safekids.org](http://www.safekids.org)



**1**  
**Important**



**1 Important**

## ***Certification***

This child restraint meets or exceeds all applicable requirements of Federal motor vehicle safety standard 213 for use in motor vehicles.



This car seat is certified for use in aircraft when using the harness system and without using the lockoff. Use only on forward-facing aircraft seats. Follow the instructions for vehicle installation and section 9-E for routing the aircraft lap belt over the lockoff. For rear-facing installation, see section 3-C and for forward-facing installation, see section 4-C but do not use the tether. See section 9-D “Vehicle Seat Belts” and section 9-E “Aircraft Installation”. Contact the airline for their specific policies.



This car seat is NOT certified for use in aircraft when using the lockoff OR when used as a booster seat because aircrafts do not have shoulder belts.

## ***Car Seat's Useful Life***

STOP using this car seat and throw it away 10 years after the date of manufacture. Look for this sticker on the bottom of the car seat.

Graco Children's Products Inc. advises against loaning or passing along a car seat unless you know the complete history of the product. We also advise against purchasing a car seat second hand.

### ***Vehicle Seat Protection***

Protect vehicle seat. Use a car seat mat, towel, or thin blanket under and behind car seat.

### ***Warm Weather Use***

Car seat parts can get very hot in the sun or warm weather. **To avoid burns, always check before putting child in car seat.**

## **1-E Safety Warnings**

**No car seat can guarantee protection from injury in every situation, but proper use helps reduce the risk of serious injury or death. **READ THIS MANUAL CAREFULLY.****



**1** Important



**1** Important

## **! WARNING!**

**Failure to follow these instructions and child restraint's labels can result in child striking the vehicle's interior during a sudden stop or crash.**



**! NEVER PLACE THIS CHILD RESTRAINT REAR-FACING IN A VEHICLE SEATING LOCATION THAT HAS AN ACTIVE FRONT AIR BAG.**

If an air bag inflates, it can hit the child and car seat with great force and cause serious injury or death to your child.





**1** Important

- ! Review your vehicle owner's manual for more information about air bags and car seat use.**
- ! If your vehicle does not have a back seat, review your vehicle owner's manual.**
- ! Children are safer riding rear-facing and should ride rear-facing as long as possible, until they reach the maximum rear-facing height or weight rating for their car seat. Then children should ride forward-facing, using the built-in harness system for as long as possible until they reach the maximum forward-facing weight or height for their car seat. At that point, children should ride in a belt-positioning booster seat. A booster is no longer needed once the vehicle seat belt fits properly, typically when they reach 4 feet 9 inches (145 cm) tall and are between ages 8-12. Be sure to check your local and state laws, as well as AAP and NHTSA recommendations, for car seat usage.\***
- ! Choose the correct mode of use for the car seat depending on your child's size. Infants less than 22 lb (10 kg) MUST use this car seat rear-facing.**

\*Graco Supports the American Academy of Pediatrics and National Highway Traffic Safety Administration's Car Seat Guidelines. Visit [www.gracobaby.com/en-US/safety](http://www.gracobaby.com/en-US/safety) for information on car seat usage recommendations.



**1 Important**

**1**

- ! Select a suitable location for the car seat in your vehicle.**
- ! Secure car seat with a vehicle seat belt or lower anchor attachment that is properly routed as shown in this manual.**
- ! Vehicle seat belt system MUST hold car seat securely. Not all vehicle seat belts can be used with a car seat.**
- ! If vehicle seat belt does not hold car seat securely, read “Vehicle Seat Belts” section 9-D and your vehicle owner’s manual.**
- ! Always secure car seat with lower anchor attachment or a vehicle seat belt, even when unoccupied. In a crash, an unsecured car seat can injure passengers.**
- ! If car seat is in a crash, it must be replaced. DO NOT use it again! A crash can cause unseen damage and using it again could result in serious injury or death.**
- ! DO NOT use car seat if it is damaged or missing parts.**
- ! DO NOT use accessories or parts other than those provided by Graco except for a thin towel or mat to protect your vehicle seat or rolled towels or pool noodles to help get your car seat level. Their use could alter the performance of the car seat.**

**! DO NOT remove LATCH system from car seat. If using vehicle seat belt to secure car seat, lower anchor connectors must be stored.**

**! Never leave child unattended, even when sleeping. Child may become tangled in harness straps and suffocate or strangle.**

**! Rear-facing car seat must be properly leveled:**

- Too reclined can result in injury or ejection.
- Too upright can result in breathing difficulties.



**! Never attach two lower anchor connectors to one vehicle lower anchor point unless specifically allowed by the vehicle manufacturer.**

**! Do not use both the vehicle seat belt and lower anchor attachment at the same time when using the car seat forward-facing with the 5-point harness.**



**1 Important**

## 2-A Car Seat Features



2 Features

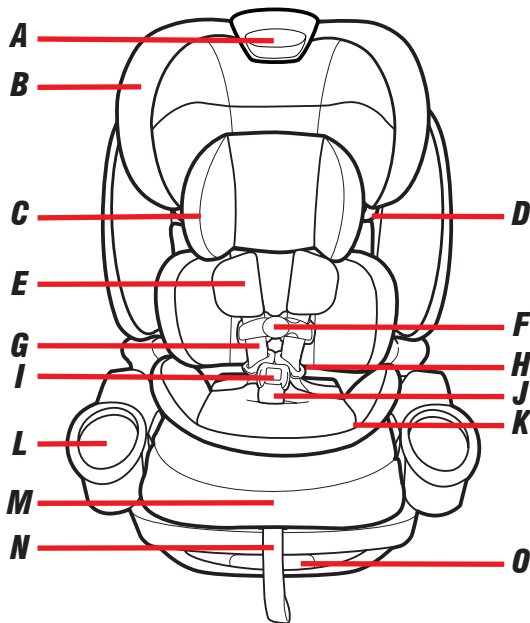

**A Headrest/Harness Height Adjustment Lever**

*(With Grow Technology, the backrest will move outward as the headrest moves up)*

**B Headrest**

**C Infant Head and Back Support**

**D Booster Shoulder Belt Guide**

**E Harness Covers**

**F Chest Clip**

**G Harness Straps**

**H Buckle Tongues**

**I Buckle**

**J Buckle Strap**

**K Infant Lower Body Support**

**L Cup Holder**

**M Harness Adjustment Lever**

*(Under Seat Pad)*

**N Harness Adjustment Strap**

**O Recline Handle**

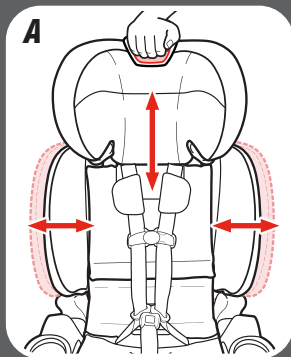

**2** Features



## 2 Features

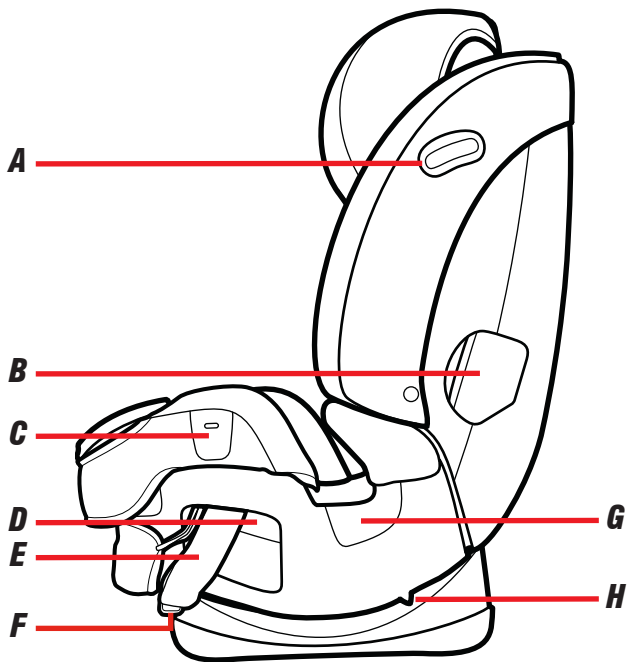

- A Level Indicator**
- B Forward-Facing Belt Path**
- C Buckle Tongue Storage** (*Fuss Free Harness*)
- D Rear-Facing Belt Path**
- E Lower Anchor Strap**
- F Rear-Facing Lower Anchor Connector Storage** (*Under Seat*)
- G Booster Lap Belt Path**
- H Recline Position Indicator**



**2** Features



## 2 Features

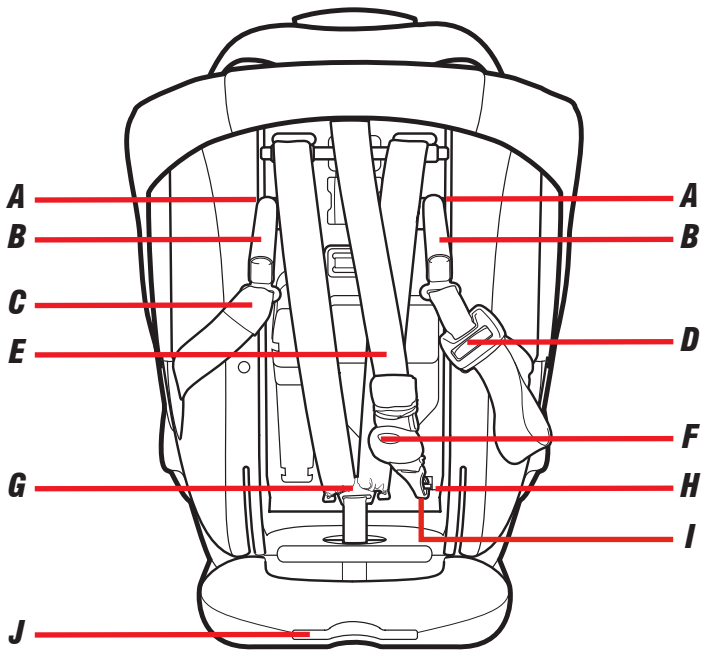



- A Forward-Facing Lower Anchor Connector Storage**
- B Lower Anchor Connectors**
- C Lower Anchor Strap**
- D Lower Anchor Strap Adjuster**
- E Tether Strap**
- F Tether Strap Adjuster**
- G Harness Strap Splitter Plate**
- H Tether Storage**
- I Tether Hook**
- J Instruction Manual Storage**



**2** Features



## 2 Features

### ***With Seat Pads Removed:***

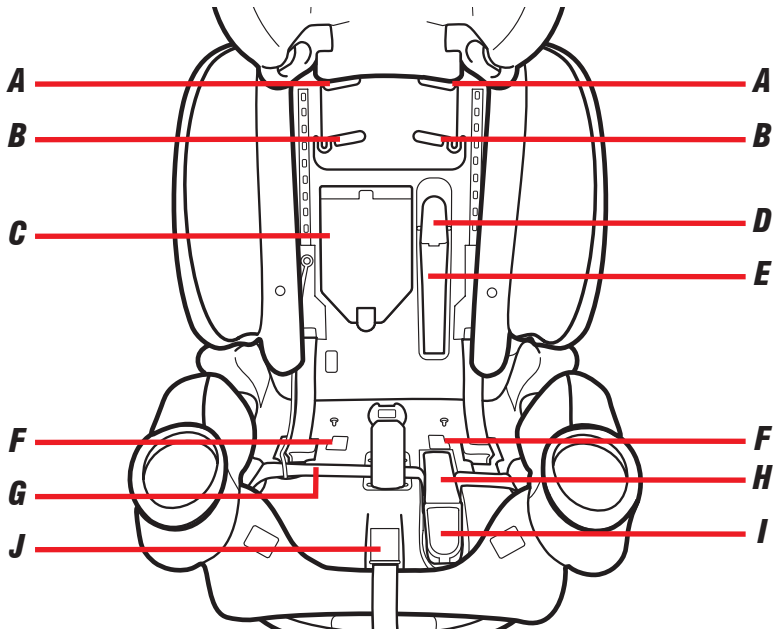

- A Upper Harness Slots**  
*(under backrest pad)*
- B Lower Harness Slots**  
*(under backrest pad)*
- C Harness Storage Compartment**
- D Forward-Facing SnugLock® Lock-Off Release Button**
- E Forward-Facing SnugLock® Lock-Off**
- F Backrest Locks**
- G Lower Anchor Strap**
- H Rear-Facing SnugLock® Lock-Off**
- I Rear-Facing SnugLock® Lock-Off Release Button**
- J Harness Adjustment Lever**



## 3-A Rear-Facing Use

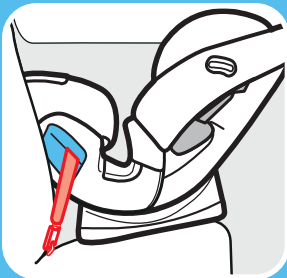

### Lower Anchor Attachment

**Do not install by this method for a child weighing more than 35 lb (16 kg)**

Visit [www.gracobaby.com](http://www.gracobaby.com) and the Graco® 4Ever® DLX SnugLock® Grow™ 4-in-1 Car Seat product page to view installation videos.

**Rear-Facing:**  
**4-40 lb (1.8-18 kg) and whose head is at least 1" (2.5 cm) below the headrest adjustment handle**



- Infants who weigh less than 22 lb (10 kg) **MUST be rear-facing.**
- Place car seat rear-facing in the vehicle back seat.
- Make sure lower anchor strap or vehicle seat belt is routed through the rear-facing belt path marked with a blue label.
- Install this car seat tightly in your vehicle. Car seat **should not move** at the rear-facing belt path more than 1" (2.5 cm) from side to side, front to back.
- Check recline level making sure the bubble is within the blue area. Vehicle **MUST** be on level ground.
- Harness straps need to be **at or just below** the top of child's shoulders and chest clip is at **armpit level.**

- Recheck the level indicator with child in seat.
- Children are safer riding rear-facing and should ride rear-facing as long as possible, until they reach the maximum rear-facing height or weight rating for their car seat. Then children should ride forward-facing, using the built-in harness system for as long as possible until they reach the maximum forward-facing weight or height for their car seat. Be sure to check your local and state laws, as well as AAP and NHTSA recommendations, for car seat usage.

**⚠ WARNING!**



**NEVER** place this child restraint rear-facing in a vehicle seating location that has an active front air bag.

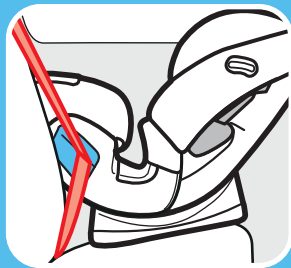

***Vehicle Seat Lap/  
Shoulder Belt***

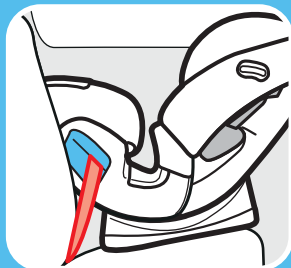

***Vehicle Seat Lap Belt***



**3-A Rear Facing**

## 3-B Install Rear-Facing with Lower Anchor Attachment

*Review your vehicle owner's manual for lower anchor location and use. Do not install by this method for a child weighing more than 35 lb (16 kg).*

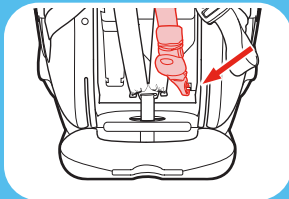

### 1. Store Tether Strap

Attach tether hook to the plastic bar on the back of the car seat as shown.

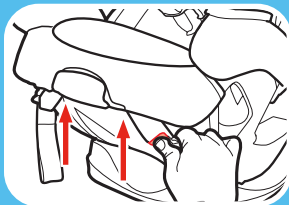

### 2. Remove Lower Anchor Connectors from Storage Location

Push in on the red buttons on the lower anchor connectors and remove from storage position.

Visit [www.gracobaby.com](http://www.gracobaby.com) and the Graco® 4Ever® DLX SnugLock® Grow™ 4-in-1 Car Seat product page to view installation videos.

### 3. **Make Sure the Lower Anchor Strap is in the Rear-Facing Belt Path Marked With a Blue Label**

To move the lower anchor attachment, review section 7.

### 4. **Recline the Car Seat**

Pull out the recline handle and place the car seat in 1st, 2nd or 3rd recline position.

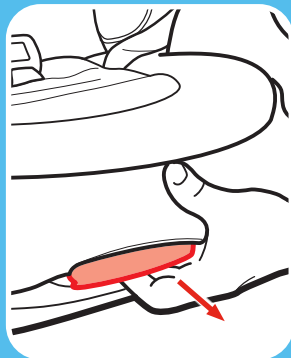
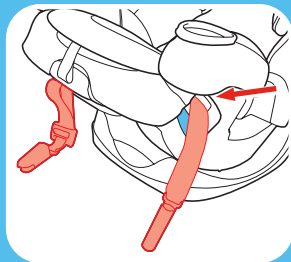
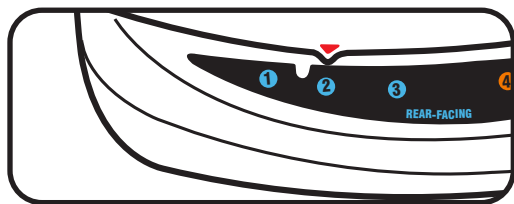

**3-B**  
Rear Facing  
with Lower Anchor  
Attachment

## 3-B Rear Facing with Lower Anchor Attachment

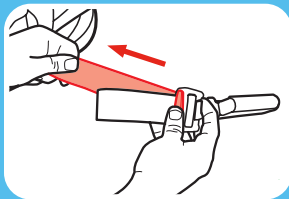
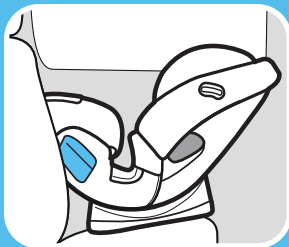

### 5. Place Car Seat Rear-Facing in Back Seat of the Vehicle

Place rear-facing in vehicle seat and center the car seat between the lower anchors. The base should sit as flat as possible on the vehicle seat.

**Note:** Make Sure Base is a minimum of 80% on Vehicle Seat.

### 6. Extend the Lower Anchor Strap

For easier installation, extend the lower anchor strap to its maximum length by pressing the grey button and pulling on the strap.

### 7. Check the Level Indicator

Vehicle **MUST** be on level ground.

Check the level indicator on the car seat. The **bubble must be completely within** the blue zone.

If needed, rolled towels may be placed under the car seat at the vehicle seat crease, until the ball is completely in the blue area.





## Using With the Belt Lock-Off:

### 8. Expose the Belt Lock-Off

- A.** Loosen the harness straps.
- B.** Raise the headrest to the highest position.
- C.** Unbuckle the buckle.
- D.** Unbuckle the chest clip.

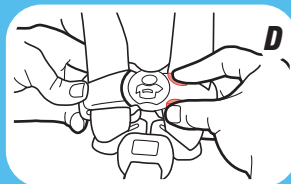
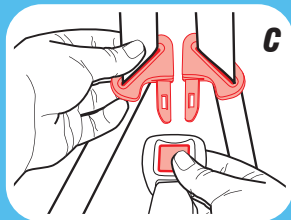
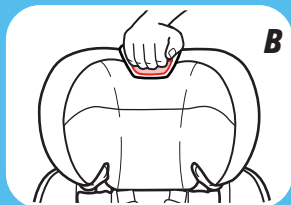
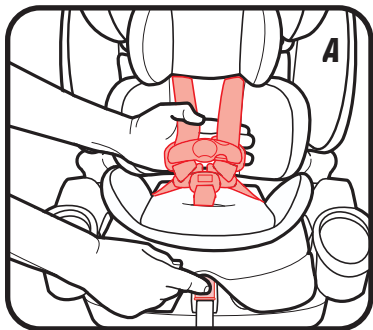

**3-B**

**Rear Facing  
with Lower Anchor  
Attachment**

**3-B**  
Rear Facing  
with Lower Anchor  
Attachment

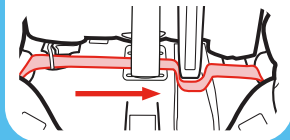
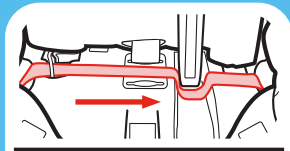
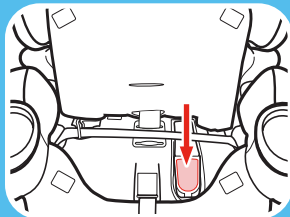
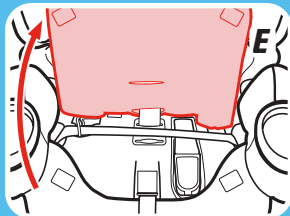

**E.** Lift Bottom Seat Pad Up To Expose the Plastic Shell

**9. Open the SnugLock® Lock-Off**

Lift the lever to open the SnugLock® lock-off.

**10. Make Sure the Lower Anchor strap is Routed Under the SnugLock® Lock-Off**

The lower anchor strap should lie as flat as possible and not be twisted.

Make sure the lower anchor strap is in front of the buckle strap when the buckle is in the inner-most position, and behind when in the outer-most position.

## 11. Connect the Lower Anchor Connectors to Vehicle's Lower Anchors

Make sure the arrows are pointing up.

Lower anchor strap should not be twisted. If twisted, you will not be able to tighten the strap.

**Lower anchor connectors can only be used if the vehicle lower anchor spacing is 11 inches (28 cm) from the center of one lower anchor to the center of the other lower anchor.**

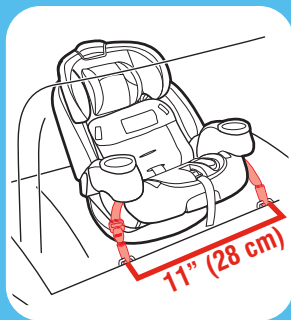
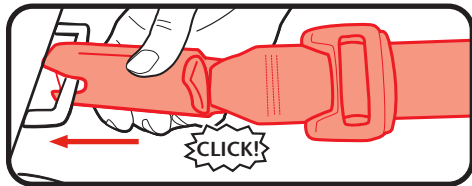
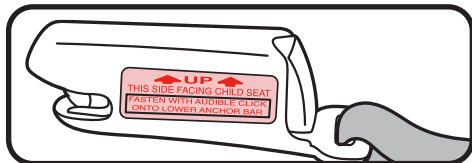

**3-B**

**Rear Facing**  
with Lower Anchor  
Attachment

**3-B**  
Rear Facing  
with Lower Anchor  
Attachment

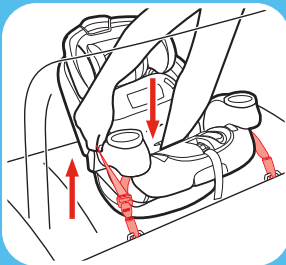
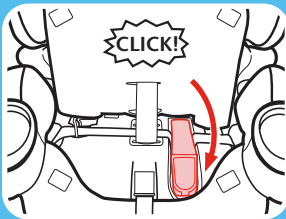

**12. Tighten the Lower Anchor Strap**

Press down firmly in the center of the car seat while tightening the lower anchor strap. You may need to tighten through the belt path as shown. Do not pull on the strap with excessive force.

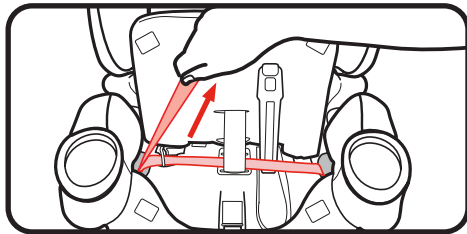

**13. Close the SnugLock® Lock-Off**

When the slack is removed, close the SnugLock® Lock-Off until you hear a “Click”. Make sure the Lower Anchor strap is under the SnugLock® Lock-Off.

**! WARNING!**

**Keep hands away from the lock-off area when closing the lock-off.**

#### 14. Test For Tightness

Grab the sides of the seat where the lower anchor strap is and slide the car seat side-to-side and front-to-back.

If the seat moves less than 1" (2.5 cm), it is tight enough.

#### 15. Replace the Seat Pad

Move the headrest back to its proper position for your child.

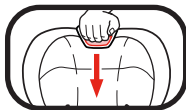

#### 16. Check the Level Indicator

Vehicle **MUST** be on level ground.

Check the level indicator on the car seat. The **bubble must be completely within the blue zone**. Readjust if needed.

See section 5-A to secure your child.

Recheck the level indicator with child in seat.

If needed, rolled towels may be placed under the car seat at the vehicle seat crease, until the ball is completely in the blue area.

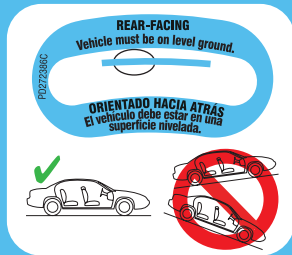
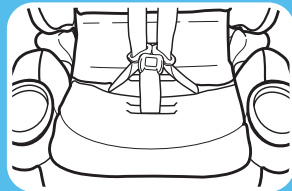
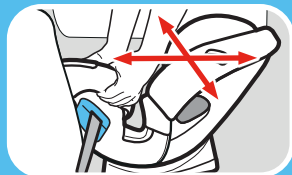

3-B

Rear Facing  
with Lower Anchor  
Attachment

**3-B**  
Rear Facing  
with Lower Anchor  
Attachment

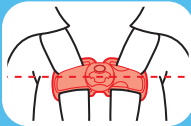
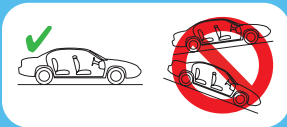

**Is Everything Correct?**

**Car Seat Does Not Move More than 1" (2.5 cm) at the Belt Path**

**Level Indicator's Bubble in the Blue Zone and Vehicle on Level Ground**



**Harness Straps at or Just Below the Child's Shoulders**

Review section 5

**Chest Clip Even With Armpits**

Review section 5

**Cannot Pinch Harness Straps at the Shoulder**

Review section 5

## 3-C Install Rear-Facing with Vehicle Seat Belt

1. **Make Sure the Lower Anchor Strap is in the Forward-Facing Belt Path Marked with an Orange Label**

To move the lower anchor attachment, review section 7.

2. **Store Tether and Lower Anchor Connectors in Storage Locations**

Attach tether hook and lower anchor connectors to the plastic bars as shown.

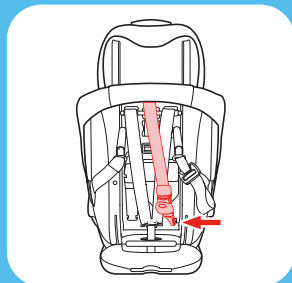
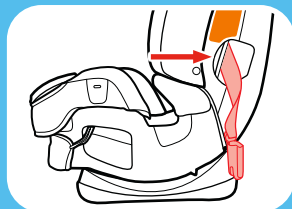
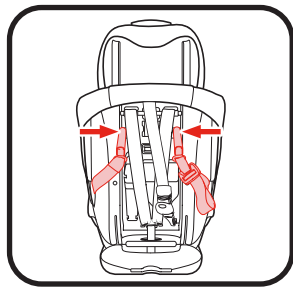

Visit [www.gracobaby.com](http://www.gracobaby.com) and the Graco® 4Ever® DLX SnugLock® Grow™ 4-in-1 Car Seat product page to view installation videos.

## 3-C Rear Facing with Seat Belt

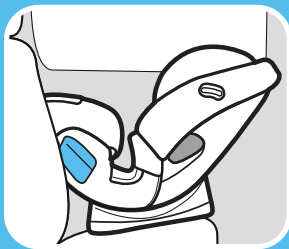
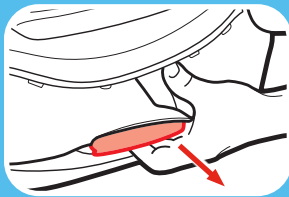

### 3. Recline the Car Seat

Pull out the recline handle and place the car seat in 1st, 2nd or 3rd recline position.



### 4. Place Car Seat Rear-Facing in Back Seat of the Vehicle

Place rear-facing in vehicle seat. The base should sit as flat as possible on the vehicle seat.

**Note:** Make Sure Base is a minimum of 80% on Vehicle Seat.

### 5. Check the Level Indicator

Vehicle **MUST** be on level ground.

Check the level indicator on the car seat. The **bubble must be completely within** the blue zone.

Adjust the recline until the bubble is completely within the blue zone.

If needed, rolled towels may be placed under the car seat at the vehicle seat crease, until the ball is completely in the blue area.





**Using With the Belt Lock-Off:**

**6. Expose the Belt Lock-Off**

- A.** Loosen the harness straps.
- B.** Raise the headrest to the highest position.
- C.** Unbuckle the buckle.
- D.** Unbuckle the chest clip.

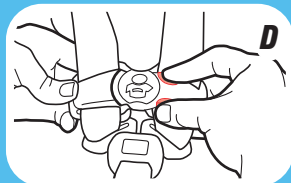
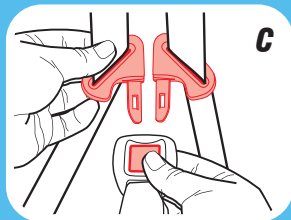
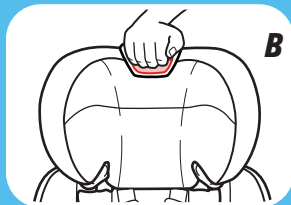
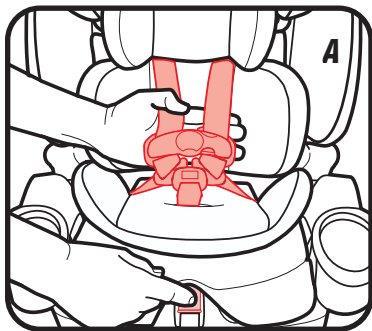



## 3-C Rear Facing with Seat Belt

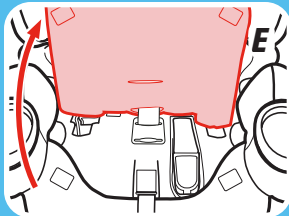

**E.** Lift bottom seat pad up to expose the plastic shell.

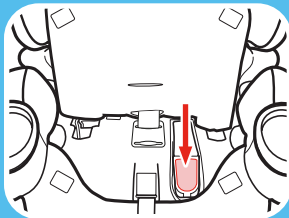

### **7. Open the SnugLock® Lock-Off**

Lift the lever to open the SnugLock® lock-off.

**Review your vehicle owner's manual for vehicle seat belt use**

### **8. Route the Vehicle Seat Belt Under the SnugLock® Lock-off**

Thread vehicle seat belt through the rear-facing belt path (marked with a blue label), through the SnugLock® Lock-Off, and out the other side. Buckle the seat belt. The seat belt should lie as flat as possible and not be twisted.

Make sure the vehicle seat belt is in front of the buckle strap when the buckle is in the inner-most position, and behind when in the outer-most position.

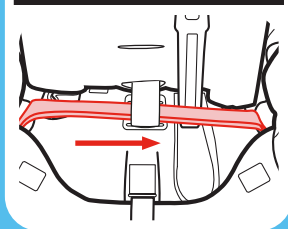
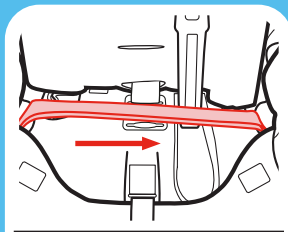
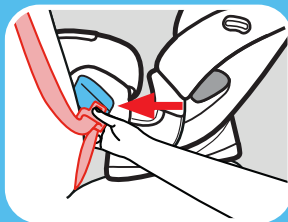

  
**3-C**  
Rear Facing  
with Seat Belt



### 3-C Rear Facing with Seat Belt

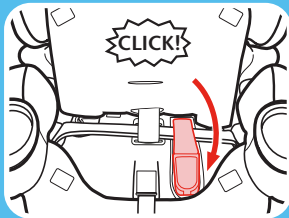
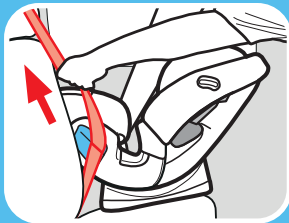

#### 9. Tighten the Vehicle Seat Belt

Press down firmly in the center of the car seat. Pull on the shoulder belt to tighten while feeding the slack back in the retractor. Do not pull on the strap with excessive force.

#### 10. Close the SnugLock® Lock-Off

When the slack is removed, close the SnugLock® Lock-Off until you hear a “Click”. Make sure the vehicle seat belt is under the SnugLock® Lock-Off.

**Note:** When using the lock-off, you are not required to switch the retractor as an installation step. The lock-off locks the seat belt. However, it is recommended to switch the retractor after the installation is complete to avoid a possible strangulation risk.

**! WARNING!**

**Keep hands away from the lock-off area when closing the lock-off.**

### 11. Test For Tightness

Grab the sides of the seat where the vehicle seat belt is and slide the car seat side-to-side and front-to-back.

If the seat moves less than 1" (2.5 cm), it is tight enough.

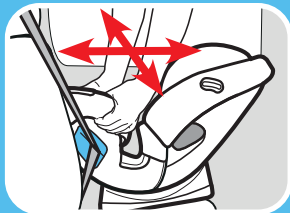

### 12. Replace the Seat Pad

Move the headrest back to its proper position for your child.

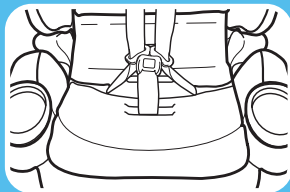
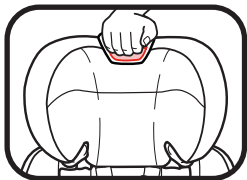

  
**3-C**  
Rear Facing  
with Seat Belt

## 3-C Rear Facing with Seat Belt

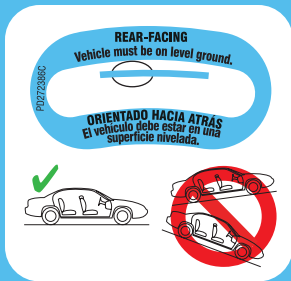

### 13. Check the Level Indicator

Vehicle **MUST** be on level ground.

Check the level indicator on the car seat. The **bubble must be completely within** the blue zone. Readjust if needed.

**See section 5-A to secure your child.**

Recheck the level indicator with child in seat.

If needed, rolled towels may be placed under the car seat at the vehicle seat crease, until the ball is completely in the blue area.



## Is Everything Correct?

**Car Seat Does Not Move More than 1" (2.5 cm) at the Belt Path**

**Level Indicator's Bubble in the Blue Zone and Vehicle on Level Ground**



**Harness Straps at or Just Below the Child's Shoulders**

Review section 5

**Chest Clip Even With Armpits**

Review section 5

**Cannot Pinch Harness Straps at the Shoulder**

Review section 5

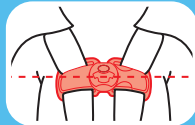
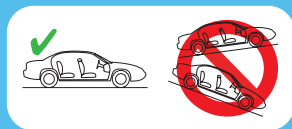

**3-C**  
Rear Facing  
with Seat Belt

## 4-A Forward-Facing Use

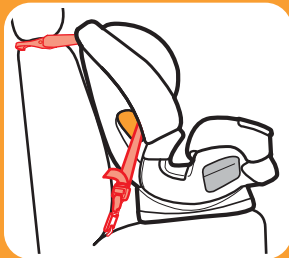

### LATCH

**Do not install by this method for a child weighing more than 40 lb (18 kg)**

Visit [www.gracobaby.com](http://www.gracobaby.com) and the Graco® 4Ever® DLX SnugLock® Grow™ 4-in-1 Car Seat product page to view installation videos.



**Forward-Facing:**  
**22-65 lb (10-30 kg)**  
**49" (125 cm) or less**

- For children 40 lb (18.1 kg) or less you **MUST** use recline positions 4 or 5.
- For children over 40 lb (18.1 kg) you **MUST** use recline position 6.
- Place car seat forward-facing in the vehicle back seat.
- Make sure lower anchor strap or vehicle seat belt is routed through the forward-facing belt path marked with an orange label.
- Install this car seat tightly in your vehicle. Car seat **should not move** at the forward-facing belt path more than 1" (2.5 cm) from side to side, front to back.
- Harness straps need to be **at or just above** the top of child's shoulders and chest clip is at **armpit level**.



- Children are safer riding rear-facing and should ride rear-facing as long as possible, until they reach the maximum rear-facing height or weight rating for their car seat. Then children should ride forward-facing, using the built-in harness system for as long as possible until they reach the maximum forward-facing weight or height for their car seat. At that point, children should ride in a belt-positioning booster seat. Be sure to check your local and state laws, as well as AAP and NHTSA recommendations, for car seat usage.

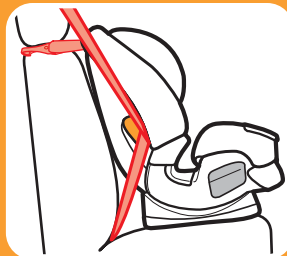

***Vehicle Lap/Shoulder Belt with Tether Strap***

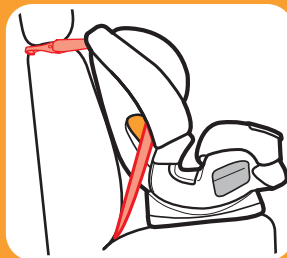

***Vehicle Seat Lap Belt with Tether Strap***



**4-A Forward-Facing**

## 4-B Install Forward-Facing with LATCH

**Review your vehicle owner's manual for LATCH location and use. Do not install by this method for a child weighing more than 40 lb (18 kg).**

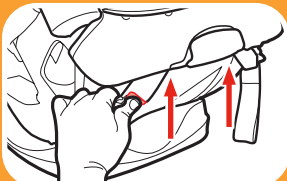

### 1. Remove Lower Anchor Connectors from Storage Location

Push in on the red buttons on the lower anchor connectors and remove from storage position.

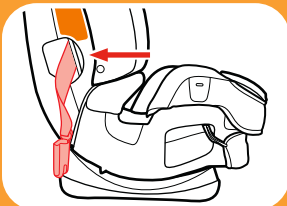

### 2. Make Sure Lower Anchor Strap is in the Forward-Facing Belt Path Marked with Orange Label

To move the lower anchor attachment, review section 7.

Visit [www.gracobaby.com](http://www.gracobaby.com) and the Graco® 4Ever® DLX SnugLock® Grow™ 4-in-1 Car Seat product page to view installation videos.

### 3. Unhook Tether Strap From Storage

Unhook tether and lay it in the seat.

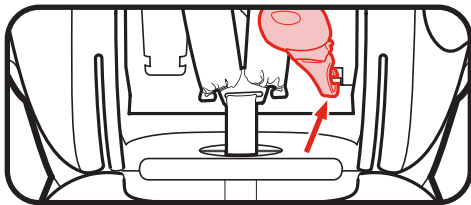

### 4. Recline the Car Seat

Pull out the recline handle and place the car seat in 4th, 5th or 6th recline position.

**For children 40 lb (18.1 kg) or less you MUST use recline positions 4 or 5.**

**For children over 40 lb (18.1 kg), MUST use recline position 6 and must install with vehicle seat belt instead of LATCH. See section 4-C.**

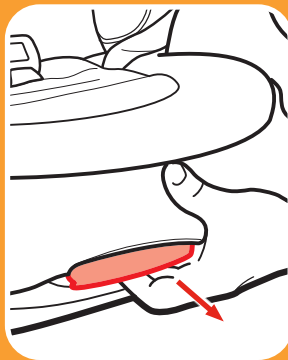
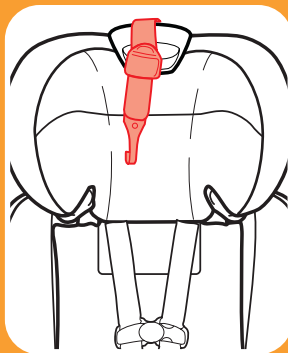
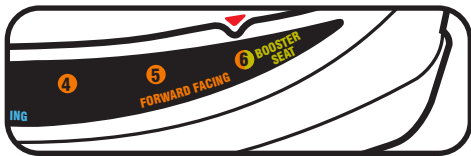

**4-B**  
Forward-Facing  
with LATCH

Forward-Facing  
4-B  
with LATCH

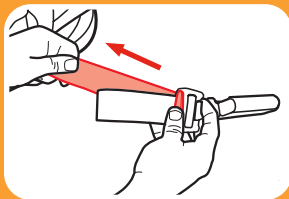

**5. Place Car Seat Forward-Facing in Back Seat of the Vehicle**

Place forward-facing in vehicle seat and center the car seat between the lower anchors. The base should sit as flat as possible on the vehicle seat.

**Note:** Make Sure Base is a minimum of 80% on Vehicle Seat.

**6. Extend the Lower Anchor Strap**

For easier installation, extend the lower anchor strap to its maximum length by pressing the grey button and pulling on the strap.

## Using With the Belt Lock-Off:

### 7. Expose the Belt Lock-Off

- A.** Loosen the harness straps.
- B.** Raise the headrest to the highest position.
- C.** Unbuckle the buckle.
- D.** Unbuckle the chest clip.

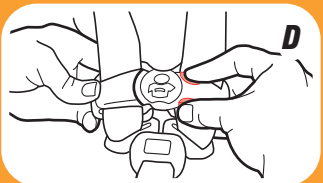
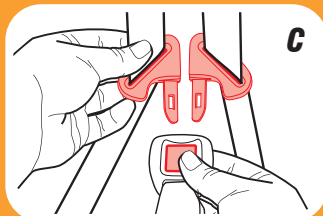
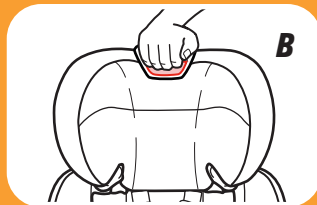
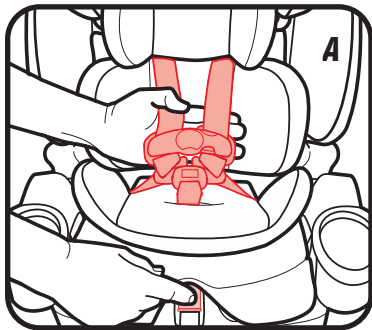

**4-B** Forward-Facing  
with LATCH

 **4-B Forward-Facing**  
with LATCH

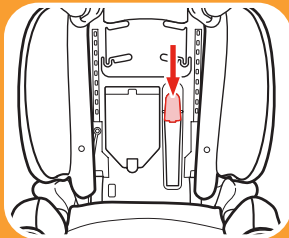
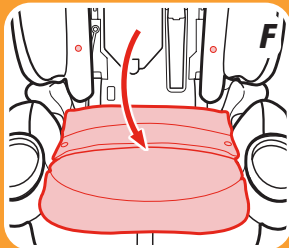
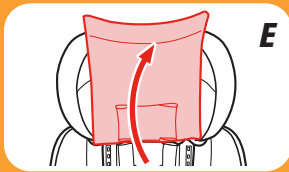

**E.** Lift the headrest pad flap up out of the way.

**F.** Unsnap bottom seat pad.

**8. Open the SnugLock® Lock-Off**

Lift the lever to open the SnugLock® lock-off.

### 9. **Make Sure the Lower Anchor Strap is Routed Under the SnugLock® Lock-Off**

The lower anchor strap should lie as flat as possible and not be twisted.

### 10. **Attach Lower Anchor Connectors to Vehicle's Lower Anchors**

Make sure the arrows are pointing up.

Lower anchor strap should not be twisted. If twisted, you will not be able to tighten the strap.

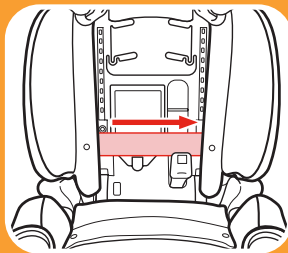

**4-B**  
Forward-Facing  
with LATCH

Forward-Facing  
4-B with LATCH

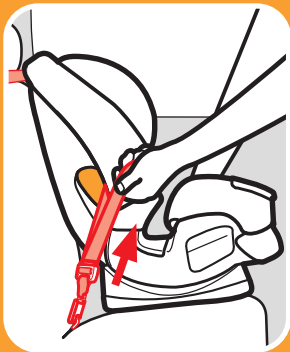
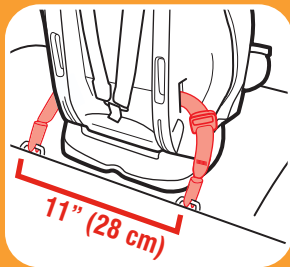

Lower anchor attachment can only be used if the vehicle lower anchor spacing is 11" (28 cm) from the center of one lower anchor to the center of the other lower anchor.

### 11. Tighten the Lower Anchor Strap

Press down firmly in the center of the car seat while tightening the lower anchor strap. You may need to tighten through the slit in the pad at the belt path as shown. Do not pull on the strap with excessive force.

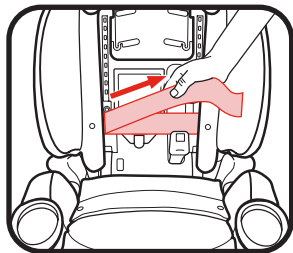



## 12. Close the SnugLock® Lock-Off

When the slack is removed, close the SnugLock® Lock-Off until you hear a “Click”. Make sure the Lower Anchor strap is under the SnugLock® Lock-Off.

**! WARNING!**

**Keep hands away from the lock-off area when closing the lock-off.**

## 13. Attach Tether Strap

Extend the tether by lifting up on the tether lock and attach.

Consult vehicle owner’s manual for specific location.

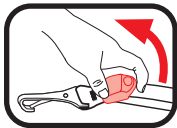

## 14. Tighten Tether Strap

Remove all the slack.

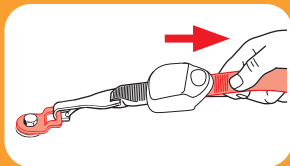
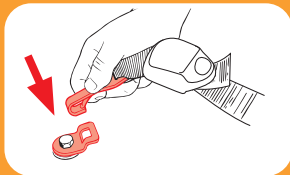
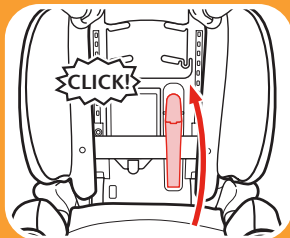

  
**4-B** Forward-Facing  
with LATCH

## 4-B Forward-Facing with LATCH

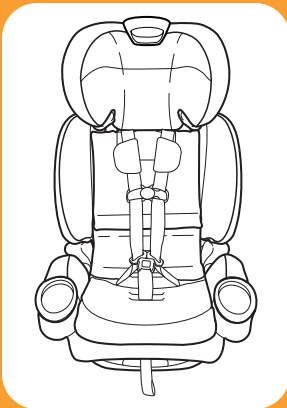

### 15. Test For Tightness

Grab the sides of the seat where the lower anchor strap is and slide the car seat side-to-side and front-to-back.

If the seat moves less than 1" (2.5 cm), it is tight enough.

**See section 5-A to secure your child.**

### 16. Replace the Seat Pad

Move the headrest back to its proper position for your child.

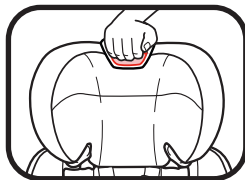



## 4-B Forward-Facing with LATCH

### ***Is Everything Correct?***

***Car Seat Does Not Move More than 1”  
(2.5 cm) at the Belt Path***



***Harness Straps at or Just Above the Child's  
Shoulders.***

Review section 5



***Chest Clip Even With Armpits***

Review section 5

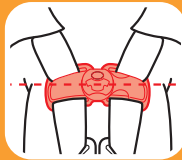

***Cannot Pinch Harness Straps at the Shoulder***

Review section 5



## 4-C Install Forward-Facing with Vehicle Seat Belt

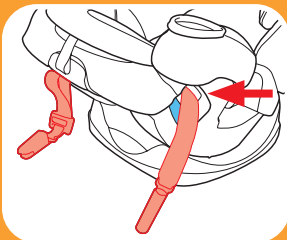

- 1. Make Sure Lower Anchor Strap is in the Rear-Facing Belt Path Marked With a Blue Label**

If not, See section 7 to move lower anchor attachment.

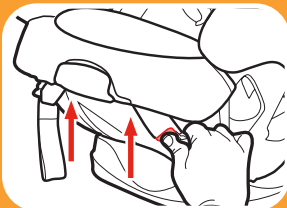

- 2. Store Lower Anchor Connectors**

Attach lower anchor connectors to the plastic bars as shown.

Visit [www.gracobaby.com](http://www.gracobaby.com) and the Graco® 4Ever® DLX SnugLock® Grow™ 4-in-1 Car Seat product page to view installation videos.

### 3. Unhook Tether Strap From Storage

Unhook tether and lay it in the seat.

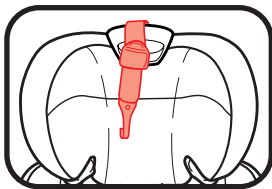

### 4. Place Car Seat Forward-Facing in Back Seat of the Vehicle

Place forward-facing in vehicle seat. The base should sit as flat as possible on the vehicle seat.

**Note:** Make Sure Base is a minimum of 80% on Vehicle Seat.

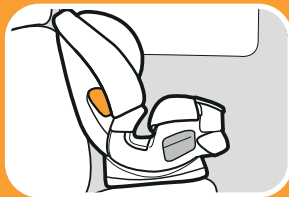
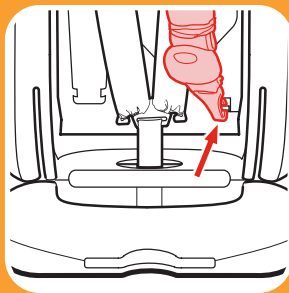

**4-C** Forward-Facing  
with Seat Belt

## 4-C Forward-Facing with Seat Belt

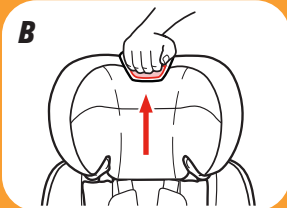
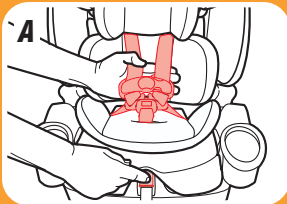
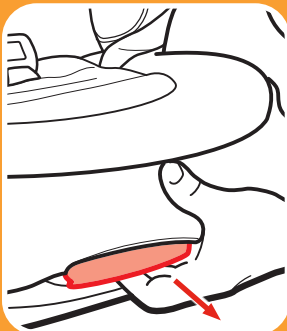

### 5. Recline the Car Seat

Pull out the recline handle and place the car seat in 4th, 5th or 6th recline position.

**For children 40 lb (18.1 kg) or less you MUST use recline positions 4 or 5.**

**For children over 40 lb (18.1 kg), MUST use recline position 6.**



**Using With the Belt Lock-Off:**

### 6. Expose the Belt Lock-Off

**A.** Loosen the harness straps.

**B.** Raise the headrest to the highest position.

**C.** Unbuckle the chest clip.

**D.** Unbuckle the buckle.

**E.** Lift the headrest pad flap up out of the way.

**F.** Unsnap Bottom Seat Pad.

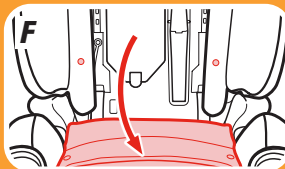
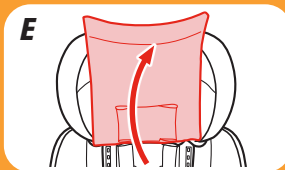
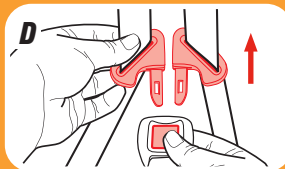
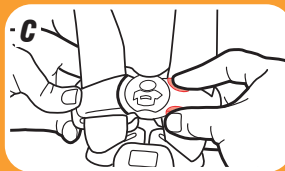

## 4-C Forward-Facing with Seat Belt



## Forward-Facing with Seat Belt

### 4-C

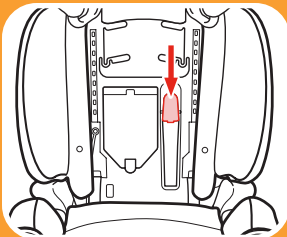

**Review your vehicle owner's manual for vehicle seat belt use**

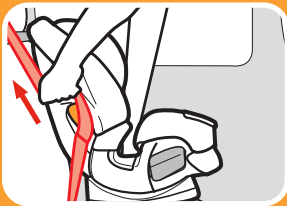
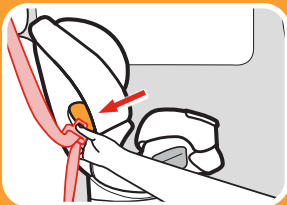

### 7. Open the SnugLock® Lock-Off

Lift the lever to open the SnugLock® lock-off.

### 8. Route the Vehicle Seat Belt

Thread vehicle seat belt through the forward-facing belt path (marked with an orange label), through the lock-off, and out the other side. Buckle the seat belt.

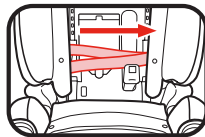

The seat belt should lie as flat as possible and not be twisted.

### 9. Tighten the Vehicle Seat Belt

Press down firmly in the center of the car seat. Pull on the shoulder belt to tighten while feeding the slack back in the retractor. Do not pull on the strap with excessive force.



### 10. Close the SnugLock® Lock-Off

When the slack is removed, close the SnugLock® Lock-Off until you hear a “Click”. Make sure the vehicle seat belt is under the SnugLock® Lock-Off.

**Note:** When using the lock-off, you are not required to switch the retractor as an installation step. The lock-off locks the seat belt. However, it is recommended to switch the retractor after the installation is complete to avoid a possible strangulation risk.

## **⚠ WARNING!**

**Keep hands away from the lock-off area when closing the lock-off.**

### 11. Attach Tether Strap

Extend the tether by lifting up on the tether lock and attach. Consult vehicle owner’s manual for specific location.

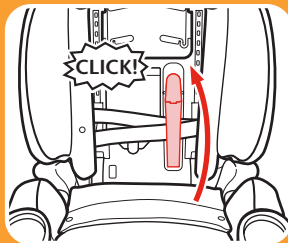
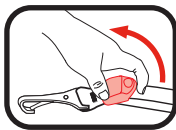

**4-C** Forward-Facing  
with Seat Belt

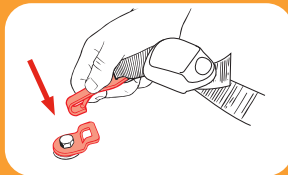

## 4-C Forward-Facing with Seat Belt

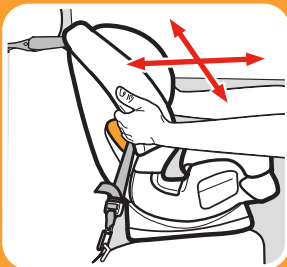
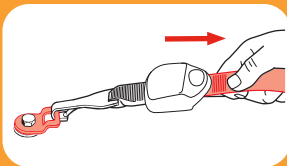

### 12. Tighten the Tether Strap

Push the car seat back while tightening the tether strap to remove all the slack.

### 13. Test For Tightness

Grab the sides of the seat where the vehicle seat belt is and slide the car seat side-to-side and front-to-back.

If the seat moves less than 1" (2.5 cm), it is tight enough.

**See section 5-A to secure your child.**

### 14. Replace the Seat Pad

Move the headrest back to its proper position for your child.

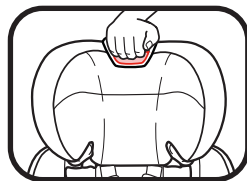

## Is Everything Correct?

**Car Seat Does Not Move More than 1" (2.5 cm) at the Belt Path**

**Harness Straps at or Just Above the Child's Shoulders.**

Review section 5

**Chest Clip Even With Armpits**

Review section 5

**Cannot Pinch Harness Straps at the Shoulder**

Review section 5

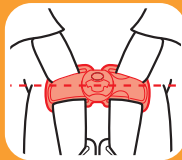

**4-C** Forward-Facing  
with Seat Belt



## **! WARNING!**

**WARNING!** In cold weather, do not put snowsuits or bulky garments on your child when placing them in the car seat. Bulky clothing can prevent the harness straps from being tightened properly. To keep child warm, buckle your child in the car seat and place a blanket around the child or place the child's coat on backwards after buckling in.



## 5-A Securing Child 5-Point Harness

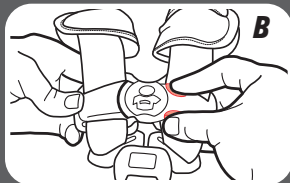
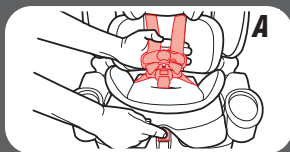

### 1. Loosen Harness Straps

**(A)** Push down on the harness release lever while pulling out on the harness straps at the chest clip.

**(B)** Unbuckle the chest clip and the buckle. **(C)** Place harness straps off to the sides.

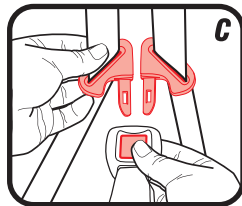



## 5 Securing Child 5-Point Harness

### 2. Buckle Storage Pockets

Place harness straps in the buckle storage pockets on both sides of the seat.

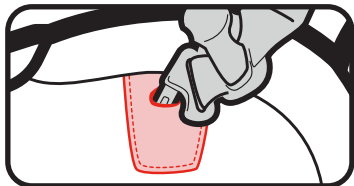

### 3. Place Your Child in the Seat

Make sure their back is flat against the car seat back.

### 4. Place Harness Straps Over Child's Shoulders and Buckle

You will hear a “click” when buckle tongues are securely attached. Pull up on each buckle tongue to make sure it is securely attached.

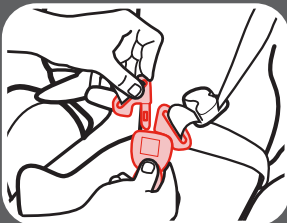
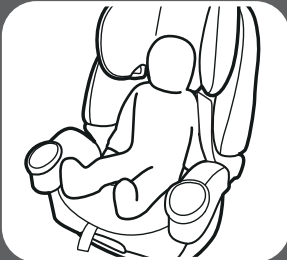
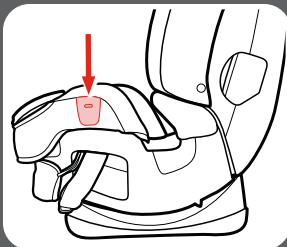

## 5 Securing Child 5-Point Harness



*Rear-Facing*



*Forward-Facing*

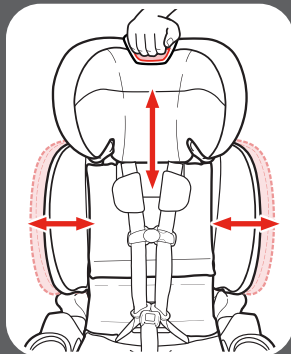

### 5. Be Sure the Harness Straps Are at the Proper Height

**Rear-Facing:** Harness straps must be **at or just below** the child's shoulders and top of head **must be at least 1" (2.5 cm) below** the headrest/harness adjustment handle.

**Forward-Facing:** Harness straps must be **at or just above** the child's shoulders and top of child's ears must be **below** top of headrest.

Remove the head and body supports.

### 6. To Raise or Lower Headrest/Harness

Squeeze the adjustment lever and lift or lower headrest for the proper harness height.

**Note:** With Grow Technology, the backrest will automatically move outward as the headrest moves up to allow for more room for your child.

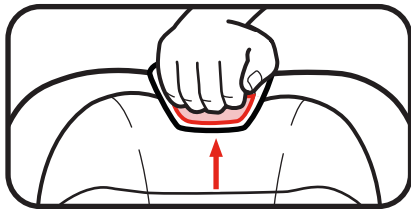

**7. Only For Smaller Infants, Rear-Facing and Under 20 lb (9 kg)**

**(Skip to step 8 if not needed)**

If child's shoulders do not reach the upper harness slots, slide the harness into the lower set of slots.

**7-A. To Change Harness Slots**

Lift the headrest pad flap out of the way.

**7-B.** From the right side, pull the harness strap out of the upper slot and slide down towards the lower slot.

**7-C.** Take the inner most edge of the harness strap and slide it into the lower slot. Check to make sure the harness strap lies flat and is not twisted.

Repeat on the other side.

**7-D.** Replace headrest pad and route harness straps into the corresponding slots as shown.

Reverse steps to use the upper harness slots.

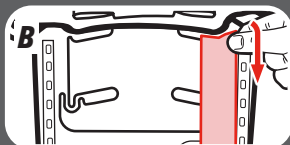
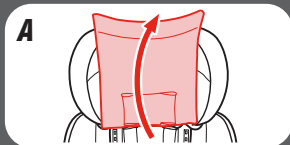
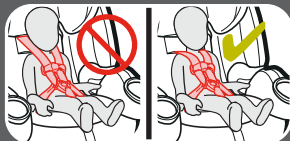

**5 Securing Child  
5-Point Harness**



## 5 Securing Child 5-Point Harness

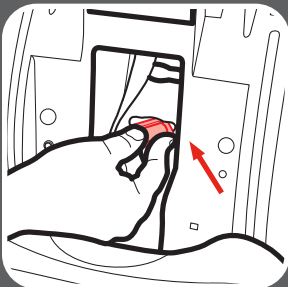
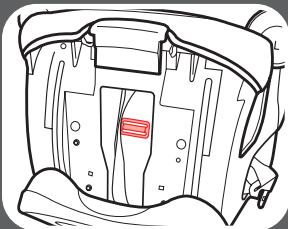
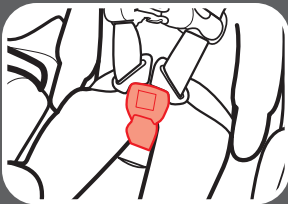

### 8. **Check the Buckle Position**

The correct slot is the one that is closest to your child without being underneath your child.

### 9. **To Adjust Buckle Strap**

*(skip to step 13 if not needed)*

Recline the car seat and locate the metal retainer under the car seat shell.

### 10. **Rotate Metal Retainer and Insert It Up Through the Shell and Pad**

From the top of the car seat, pull the buckle out.



### 11. Insert Metal Retainer in the New Buckle Strap Slot

Reach underneath the car seat and pull the metal retainer through.

### 12. Pull Up on Buckle Strap to Make Sure it is Secured

**Rear-Facing:** Make sure the lower anchor strap is in front of the buckle strap when the buckle is in the inner-most position (A), and in behind when in the outer-most position (B) and that it is flat and is not twisted.

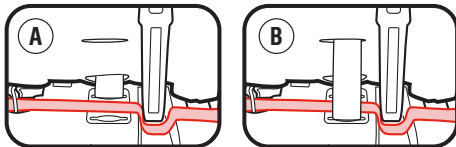

**Forward-Facing:** Make sure the lower anchor strap is routed behind the harness strap, is flat, and is not twisted.

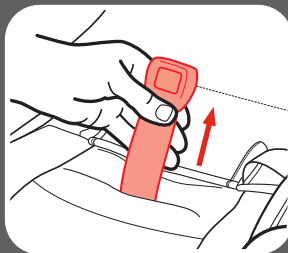
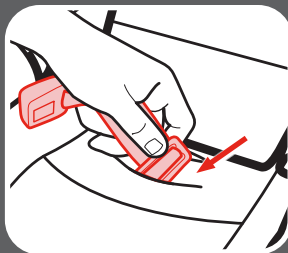

## 5 Securing Child 5-Point Harness

## 5 Securing Child 5-Point Harness

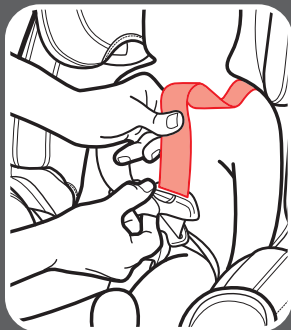
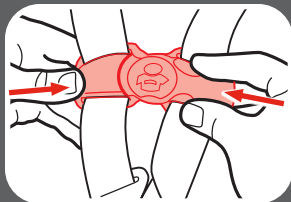

### **13. Buckle the Chest Clip**

You will hear a “click” when the chest clip is securely buckled.

### **14. Pull All the Slack Out From Around the Waist**

Pull up on the harness strap while pushing the chest clip down. Do this to both sides.

### **15. Tighten the Harness by Pulling the Harness Adjustment Strap**

When you are not able to pinch any of the harness webbing at your child's shoulder, the harness is tight enough.

A snug harness should not allow any slack. It lies in a relatively straight line without sagging. It does not press on the child's flesh or push the child's body into an unnatural position.

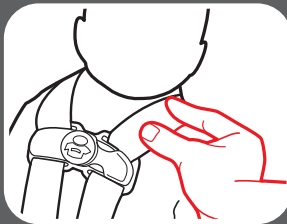
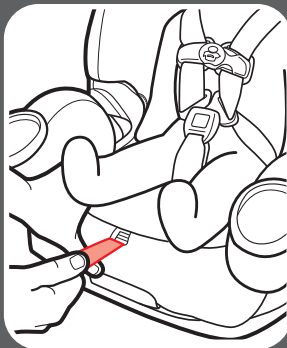

## **5 Securing Child 5-Point Harness**

**5 Securing Child  
5-Point Harness**

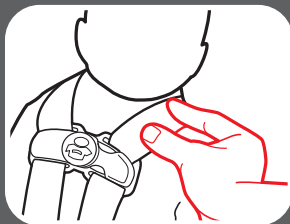
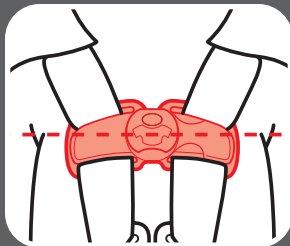

***16. Raise the Chest Clip to Child's Armpit Level***

***17. Check Tightness Again, Tighten More if Needed***

## 6-A Booster Use

**Highback Booster:**  
40-100 lb (18.1-45 kg)  
43-57" (110.1-145 cm)  
at least 4 years old



**Backless Booster:**  
40-120 lb (18.1-54 kg)  
43-57" (110.1-145 cm)  
at least 4 years old

- Place car seat forward-facing in the vehicle back seat.
- Make sure vehicle seat's lap belt is adjusted snugly and lays low on the child's hip and is routed behind the armrest in the booster's belt path marked with a green label.
- Vehicle belts **MUST** lie flat against child and **MUST NOT** be twisted.
- Vehicle seat's shoulder belt is adjusted snugly and should lie between child's neck and edge of shoulder.



**Vehicle Lap/Shoulder  
Seat Belt**



**Vehicle Seat Lap/  
Shoulder Belt**



**6-A  
Booster**



## 6-A Booster



**Never Use a Vehicle Lap-Only Belt Across Front of Child**



- **Never** use a vehicle lap-only belt across front of child.
- **DO NOT** position vehicle shoulder belt under the child's arm or back.
- **DO NOT** allow child to slouch or slide down in the booster seat.
- **DO NOT** position vehicle belt over top of armrests.
- Vehicle's seat headrest **SHOULD NOT** create a gap between vehicle seat and booster seat.
- The front of booster seat **MUST NOT** hang over front of vehicle seat.
- If child will not keep vehicle belt properly positioned, **DO NOT** use this booster seat. Use a different car seat.

When forward-facing, children should use the built-in harness system for as long as possible until they reach the maximum forward-facing weight or height for their car seat. At that point, children should ride in a belt-positioning booster seat. A booster is no longer needed once the vehicle seat belt fits properly, typically when they reach 4 feet 9 inches (145 cm) tall and are between ages 8-12. Be sure to check your local and state laws, as well as AAP and NHTSA recommendations, for car seat usage.

## 6-B Install Highback Booster

### 1. Store The Harness System

**A. Loosen the shoulder straps as much as possible.**

**B. Raise the headrest to the highest position.**

**C. Unbuckle the chest clip and the buckle strap (D).**

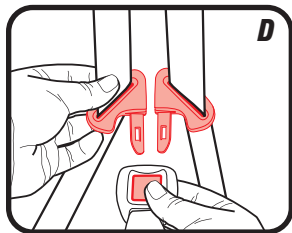
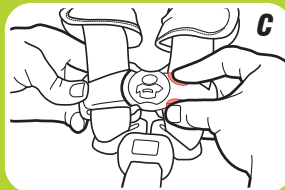
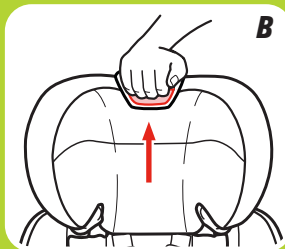
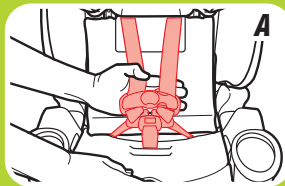

**6-B** Install Highback Booster



## 6-B Install Highback Booster

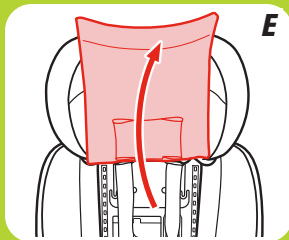

**E**

**E. Lift the headrest pad flap up out of the way**

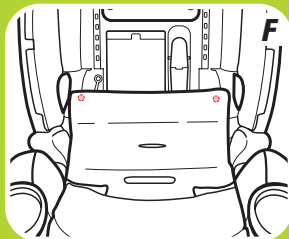

**F**

**F. Unsnap Bottom Seat Pad**

Undo the 2 snaps.

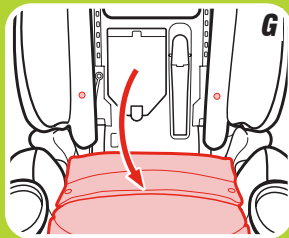

**G**

**G. Pull Bottom Seat Pad Back To Expose the  
Plastic Shell**



**H. Slide the harness straps out of the harness slots so they rest under the headrest panel as shown**

If switching back to harness mode from booster mode, make sure to slide the straps back into one of the harness slots. See section 5-A.

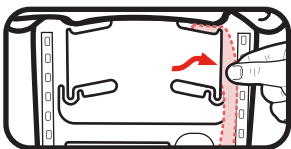

**I. Open the Harness Storage Door**

**J. Place Harness, Chest Clip, Buckle Tongues, Harness Covers Inside Storage Compartment and Close the Door**

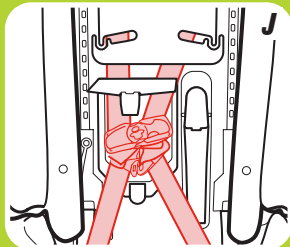
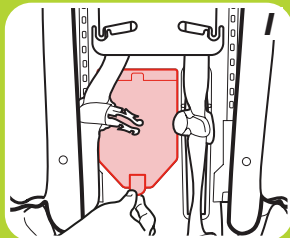
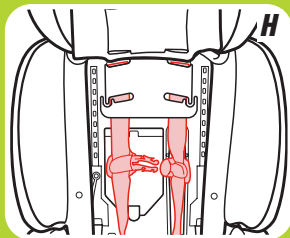
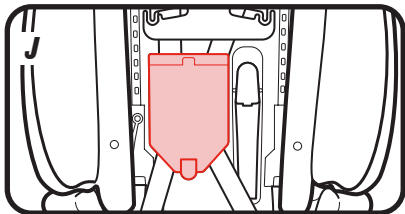

**6-B**  
Install Highback  
Booster



## 6-B Install Highback Booster

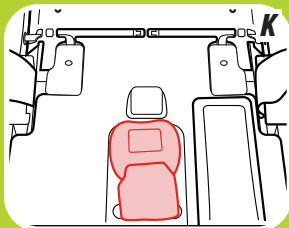

***K. Store Buckle inside the groove in the car seat shell as shown***

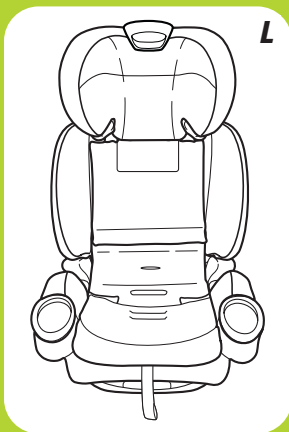

***L. Replace Seat Pad***

Move the headrest back to its proper position for your child.

## 2. Recline the Car Seat

Pull out the recline handle and place the car seat in the 6th recline position.

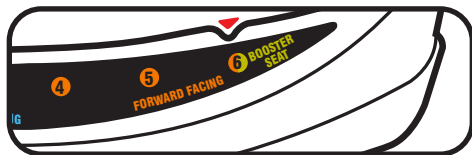

## 3. Place the Booster Seat Forward-Facing in the Back Seat of Vehicle

Place forward-facing on a vehicle seat that has a lap/shoulder seat belt. The base should sit as flat as possible on the vehicle seat.

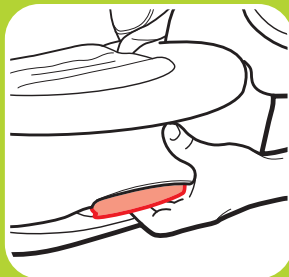

**6-B** Install Highback  
Booster



## 6-B Install Highback Booster

Graco allows the securing of the car seat with LATCH in the booster mode, only if the vehicle manufacturer allows it. The child still **MUST BE SECURED** with the vehicle lap/shoulder seat belt. LATCH can be used in the booster mode regardless of the weight of the child up to 100 lb (45 kg).

Verify the following before using LATCH in the booster mode:

- The lower anchor connectors **DO NOT** interfere with any vehicle seat belts or buckles.

If the lower anchor connector interferes with the vehicle seat belts or if the chosen seating position does not have lower anchors, you **MUST** store the lower anchor connectors. Store the lower anchor connectors by pushing in on the red buttons on the connectors and attach to the plastic bar as shown. Store the tether strap as shown. Always secure car seat with lower anchor attachment or a vehicle seat belt, even when unoccupied. In a crash, an unsecured car seat can injure passengers.

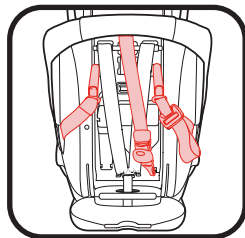

### ***Skip to Step 18 if Not Using LATCH***

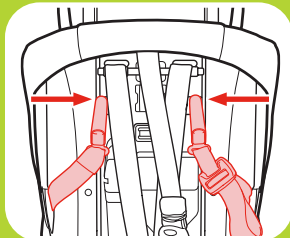

#### ***4. Remove Lower Anchor Connectors from Storage Location***

Push in on the red buttons on the lower anchor connectors and remove from storage position.

**5. Make Sure Lower Anchor Strap is in the Forward-Facing Belt Path Marked with Orange Label**

Continue to next step if correct. See section 7 if it is not.

**6. Unhook Tether Strap From Storage Location and Lay it in the Seat**

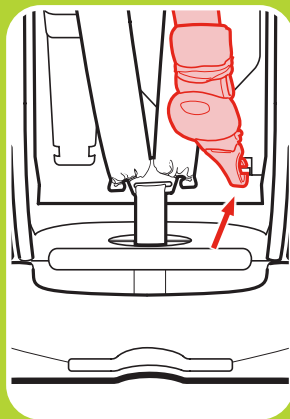
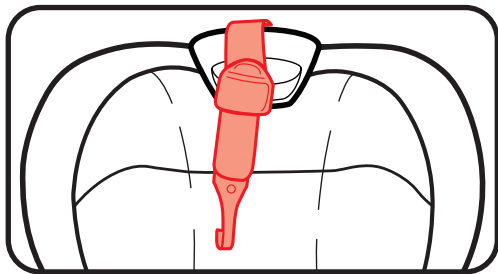

**6-B** Install Highback  
Booster



## 6-B Install Highback Booster

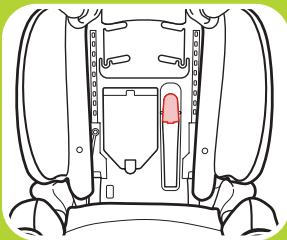
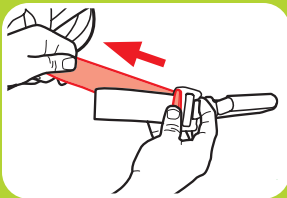

### **7. Extend the Lower Anchor Strap**

For easier installation, extend the lower anchor strap to its maximum length by pressing the grey button and pulling on the strap.

### **8. Expose the SnugLock® Lock-Off**

### **9. Open the SnugLock® Lock-Off**

Lift the lever to open the SnugLock® lock-off.

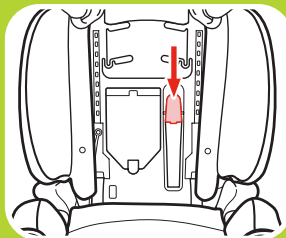

### **10. Make Sure the Lower Anchor Strap is Routed Under the SnugLock® Lock-Off**

The lower anchor strap should lie as flat as possible and not be twisted.

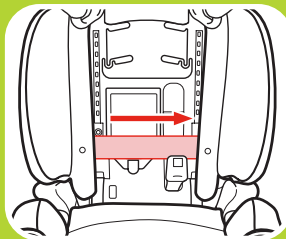

**6-B** Install Highback  
Booster



## 6-B Install Highback Booster

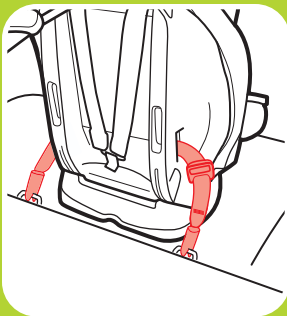

### 11. Attach Lower Anchor Connectors to Vehicle's Lower Anchors

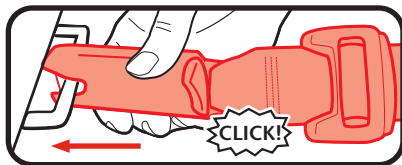

Make sure the arrows are pointing up.  
Lower anchor strap should not be twisted. If twisted, you will not be able to tighten the strap.

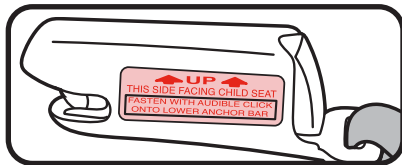



### 12. Tighten the Lower Anchor Strap

Remove all the slack from the lower anchor strap. Do not pull on the strap with excessive force.

### 13. Close the SnugLock® Lock-Off

When the slack is removed, close the SnugLock® Lock-Off until you hear a “Click”. Make sure the Lower Anchor strap is under the SnugLock® Lock-Off.

**⚠ WARNING!**

**Keep hands away from the lock-off area when closing the lock-off.**

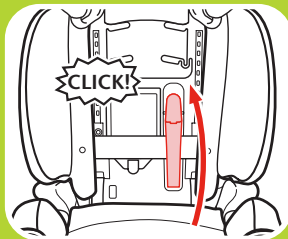
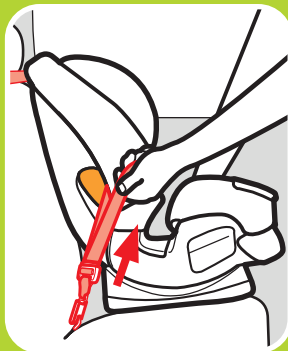

**6-B** Install Highback  
Booster

## 6-B Install Highback Booster

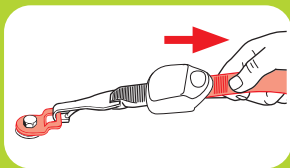
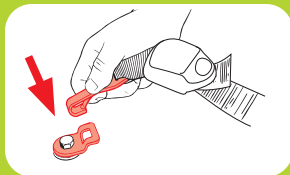

### 14. **Attach Tether Strap**

Extend the tether by lifting up on the tether lock and attach.

Consult vehicle owner's manual for specific location.

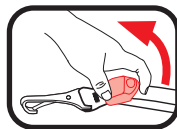

### 15. **Tighten Tether Strap**

Remove all the slack.

## **16. Replace the Seat Pad**

Move the headrest back to its proper position for your child.

## **17. Thread the Vehicle Seat Shoulder Belt Through Seat Belt Guide on the Headrest**

See section 6-D to secure your child.

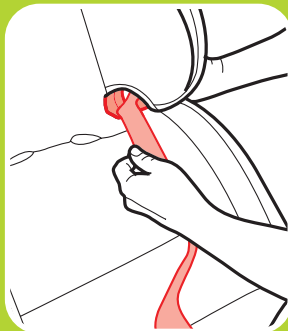
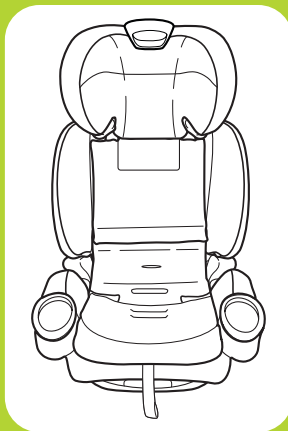

**6-B** Install Highback  
Booster



## 6-C Install Backless Booster

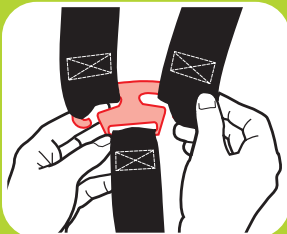
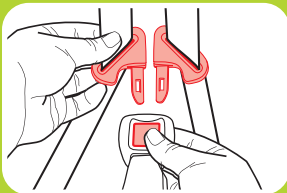
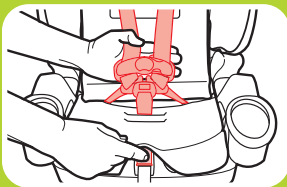

### 1. Remove the Seat Back by First Loosening the Harness Straps

Push down on the harness release lever while pulling out on the harness straps at the chest clip.



Unbuckle the chest clip and the buckle strap.

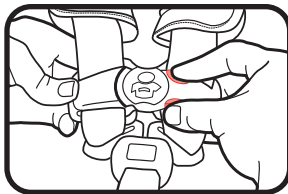

### 2. Remove Harness Straps from Splitter Plate

### **3. Make Sure Lower Anchor Strap is in the Forward-Facing Belt Path and in the Stored Position**

See section 7 to move the lower anchor attachment.

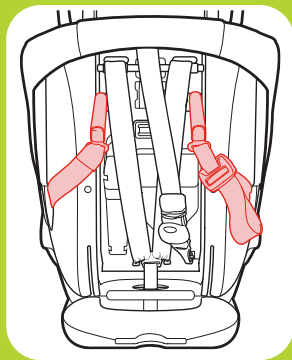

### **4. Unsnap Bottom Seat Pad**

Unsnap snaps on the back and bottom of seat pad to expose the seat base.

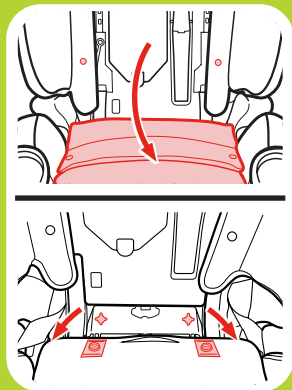

**6-C** Install Backless  
Booster

## 6-C Install Backless Booster

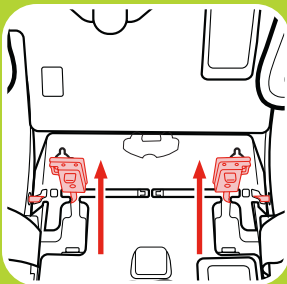
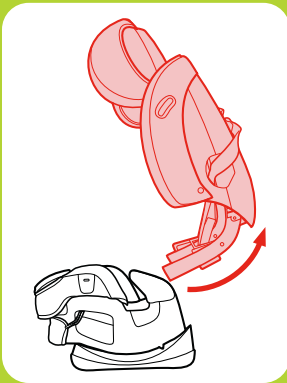

### **5. Lift the Red Backrest Lock Up**

With the car seat in the 6th recline position, lift the red backrest locks up and slide together.

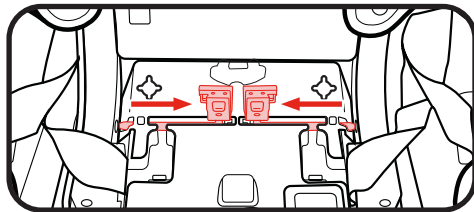

### **6. Remove Seat Back from Seat Base**

Push the seat back up and lift out of base. To replace the seat back, reverse steps 4 through 6.

### **7. Relock the Red Backrest Locks**

Make sure they are both flat and locked into place

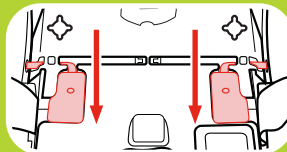

### **8. Store Splitter Plate**

Pull the harness adjustment strap all the way out and then store the splitter plate.

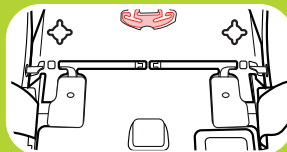

### **9. Store Buckle Strap**

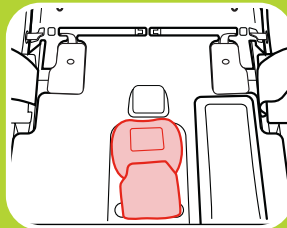

**6-C** Install Backless  
Booster

## 6-C Install Backless Booster

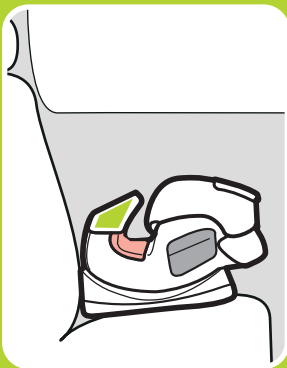
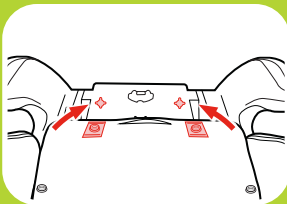

### **10. Attach Seat Pad to the Back of Base**

Reattach snaps at the bottom of seat pad to the base as shown.

### **11. Place the Booster Seat Forward-Facing in the Back Seat of Vehicle**

Place forward-facing on a vehicle seat that has a lap/shoulder seat belt. The base should sit as flat as possible on the vehicle seat.

**See section 6-E to secure your child.**



## 6-D Securing Child Highback Booster

### **⚠ WARNING!**

**Use only the vehicle lap and shoulder belt system when restraining the child in the booster seat.**

#### **1. Place Child In Seat**

Have your child sit in the booster seat, with his/her back flat against the back of the booster seat.

#### **2. Thread Vehicle's Shoulder Belt Into Seat Belt Guide in the Headrest**

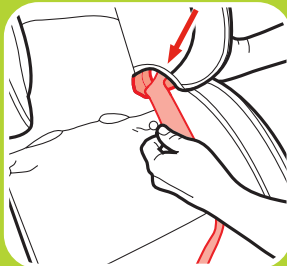
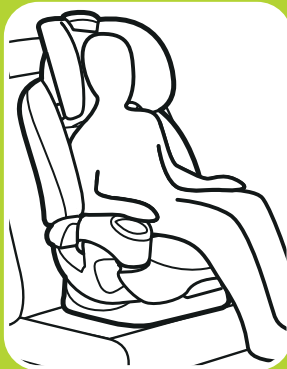

**6-D** Securing Child  
Highback Booster

**6-D** Securing Child  
Highback Booster

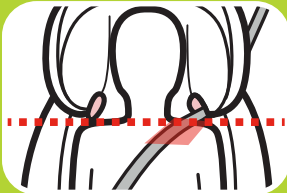
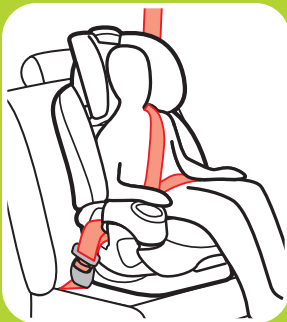

**3. Buckle the Vehicle Lap/Shoulder Seat Belt**

Be sure the lap portion of the vehicle seat belt goes behind the armrests.

Be sure the lap portion of the vehicle seat belt lies low across your child's hips.

Be sure the shoulder belt lies across your child's shoulders, between the neck and edge of shoulder. The belt guides should be even with or just above the shoulders.

## ***Is Everything Correct?***

***Never Use Lap Belt Only***



***Lap Belt Behind Armrest and Lies Low Across Hips and Thighs***

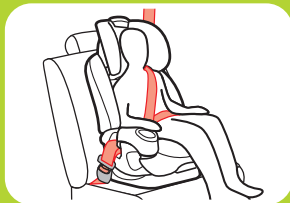

***Shoulder Belt Lies On the Shoulder, Between the Neck and Edge of Shoulders***

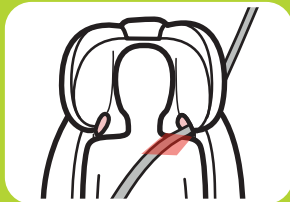

**6-D**  
**Securing Child**  
**Highback Booster**



## 6-E Securing Child Backless Booster

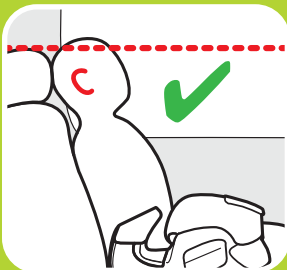

### **⚠ WARNING!**

**Use only the vehicle lap and shoulder belt system when restraining the child in the booster seat.**

#### **1. Place Child In Seat**

Have your child sit in the booster seat, with his/her back flat against the back of the vehicle seat.

#### **2. Ears Must Be Below the Top of the Vehicle Seat Back or Headrest.**

### 3. Buckle the Vehicle Lap/Shoulder Seat Belt

Be sure the lap portion of the vehicle seat belt goes behind the armrests.

Be sure the lap portion of the vehicle seat belt lies low across your child's hips.

Be sure the shoulder belt lies across your child's shoulders, between the neck and edge of shoulder.

You may need to use the belt positioning clip to help get a good fit.

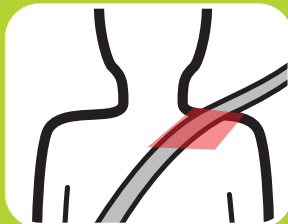
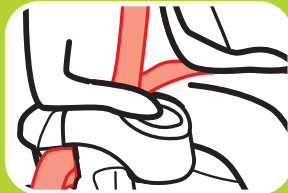

**6-E** Securing Child  
Backless Booster

**6-E** Securing Child  
Backless Booster



**Is Everything Correct?**



***Never Use Lap Belt Only***



***Lap Belt Behind Armrest and Lies Low Across Hips and Thighs***



***Shoulder Belt Lies On the Shoulder, Between the Neck and Edge of Shoulder***

## Using Belt Positioning Clip

### 1. Make Sure Vehicle's Seat Shoulder Belt Lays in the Red Zone As Shown

If the vehicle's seat shoulder belt lays outside this zone, you **MUST** use the belt positioning clip.

Do not use the belt positioning clip if the belt is already laying inside this zone.

### 2. Attach Belt Positioning Clip

Insert the loop end of the strap through the same slot as the harness adjustment strap as shown.

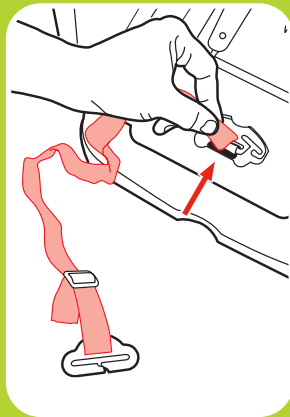
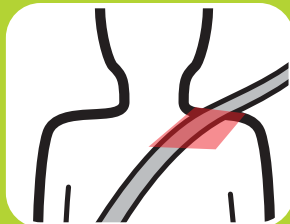

6-E Securing Child  
Backless Booster

**6-E** **Securing Child  
Backless Booster**

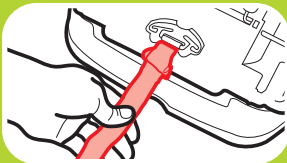
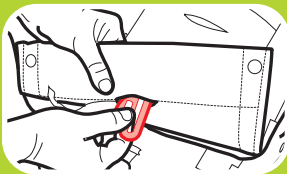
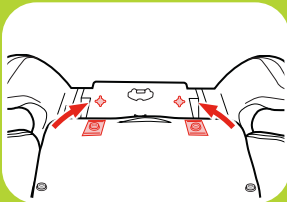

**3. Push Clip and Strap Through Loop**

**4. Pull to Tighten Strap**

**5. Push Clip Through Slot In Pad**

**6. Attach Seat Pad to Base**



## 7. Place Child in Seat, Buckle Child In Seat and Attach Belt Positioning Clip

With child's back flat against the back of the vehicle seat, buckle child in. Then slide the clip onto the vehicle's seat shoulder belt as shown.

## 8. Adjust the Belt Positioning Clip to Fit Your Child

Lengthen or shorten the belt length as shown.

Clip should fit right at the top of shoulder as shown.

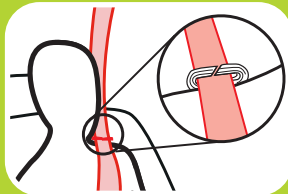
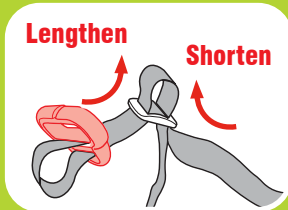
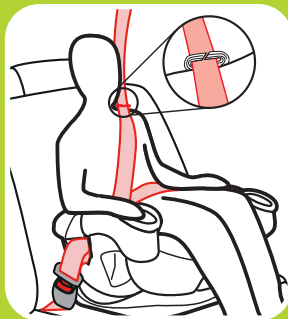

6-E Securing Child Backless Booster

## 7-A Moving the Lower Anchor Attachment

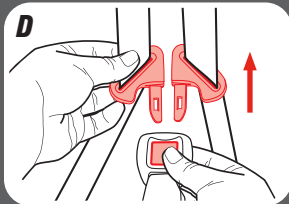
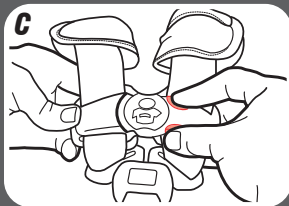
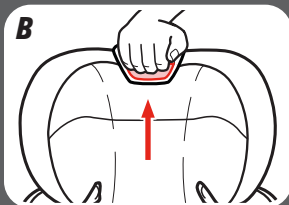

### 1. For Ease of Moving the Lower Anchor Attachment

- A.** Loosen the harness straps.
- B.** Raise the headrest to the highest position.
- C.** Unbuckle the chest clip.
- D.** Unbuckle the buckle.

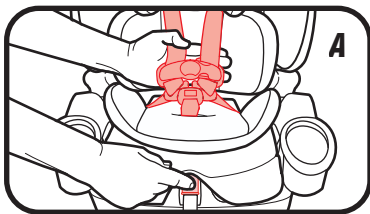

**2. Lift The Headrest Pad Flap Up Out Of The Way**

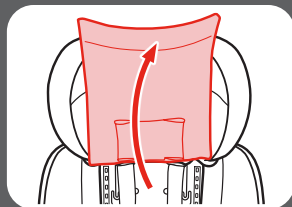

**3. Unsnap Bottom Seat Pad**

Unsnap snaps on the back and bottom of seat pad to expose the seat base.

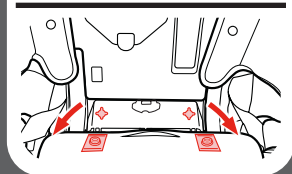
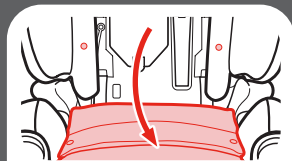

**4. Completely Remove The Seat Pad Back To Expose the Plastic Shell**

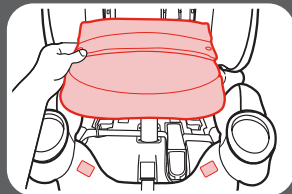

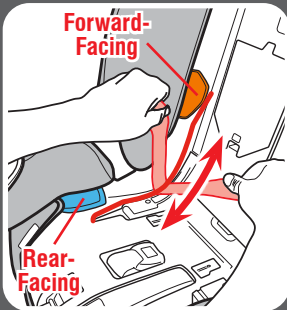
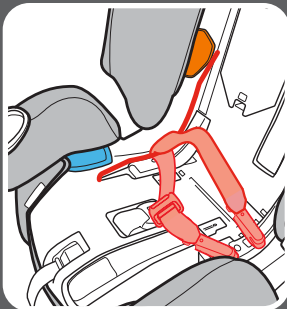

**5. Pull the Lower Anchor Connectors Out of the Belt Path Openings**

Pull the lower anchor connectors out of the belt path openings, so that the lower anchor connectors lay in the seat.

**6. Slide Entire Lower Anchor Strap Along Bar to the Desired Belt Path Openings**

**Rear-Facing:** Slide lower anchor strap along bar to the front of the seat.

**Forward-Facing:** Slide the lower anchor strap up along bar to the top.

## 7. Push the Lower Anchor Connectors Out Through the Desired Belt Path Openings on Each Side of Car Seat

**Rear-Facing:** Make sure the Lower Anchor strap is in front of the buckle strap when the buckle is in the inner-most position (A), and behind when in the outer-most position (B) and that it is flat and is not twisted.

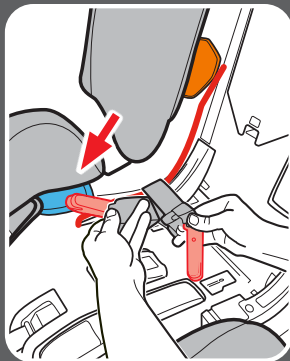
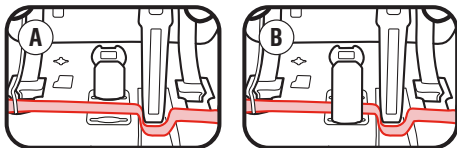

7 Moving  
Lower Anchor Attachment

## 7 Moving Lower Anchor Attachment

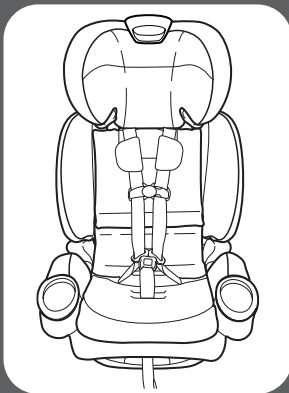
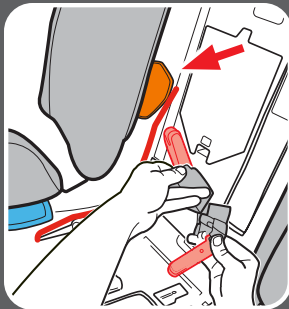

**Forward-Facing:** Make sure the lower anchor strap is routed behind the harness strap, is flat, and is not twisted.

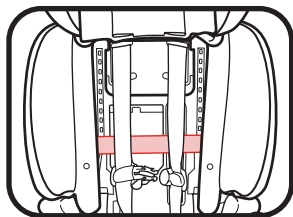

## 8. Replace the Seat Pad

**9. Move the Headrest to Its Proper Position for Your Child**

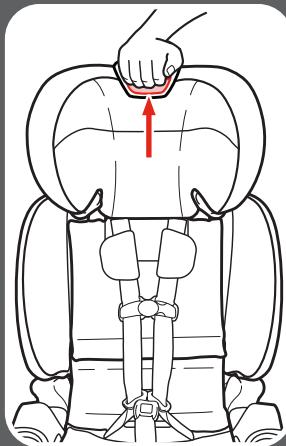

**7 Moving**  
Lower Anchor Attachment

## 8-A Accessories *(on select models)*

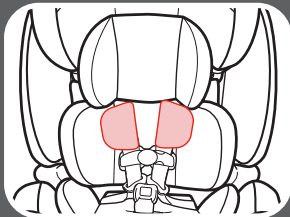

### ***Harness Covers***

The harness covers **MUST** be used when this car seat is installed in forward-facing harness mode. The bottom of the harness covers should be as close to the chest clip as possible without interfering with it being at armpit level.

Make sure the rubber sides of the harness covers are against the child's chest.

To remove, undo the fastening strips.

All infant support pieces (Head and Back Support and Lower Body Support) can only be used Rear-Facing for children weighing less than 20 lb (9 kg). Use the infant support pieces to ensure the child is secure, comfortable, and their head does not tilt forward. Use the following guidelines:



### ***Infant Head and Back Support***

The Head and Back Support **MUST** be used if using the lower harness slots.

To adjust the support, pull up until desired height.

To install, thread the head support straps through the headrest and use the fastening strips to connect the straps together.

Place the harness straps through the openings on either side and make sure the straps are routed in front of the lower portion of the support.

To remove, undo the fastening strips and pull the straps out of the headrest.

### ***Infant Lower Body Support***

The Lower Body Support **MUST** be used for children weighing less than 12 lb (5.5 kg).

The slot on the body support must align with the inner-most crotch buckle slot on the seat. Only use lower body support when the crotch buckle is in the inner-most slot.

Never allow body support to bunch or fold behind child.

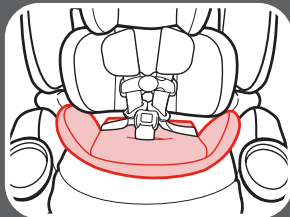
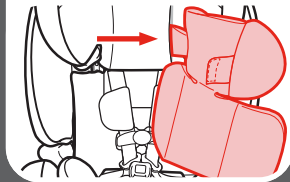
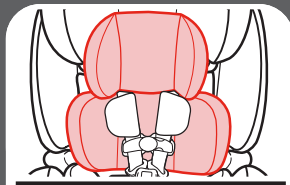

## 9-A How to Uninstall Lower Anchor Connectors and Tether

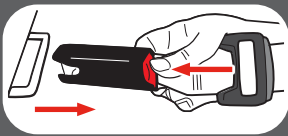

### **Lower Anchor Connectors**

To remove the lower anchor connectors from the lower anchors, push in on the red buttons and pull them off.

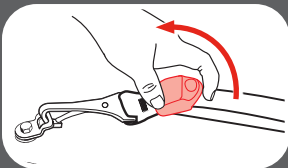

### **Tether**

To remove, lift up on the tether lock to release the tension.

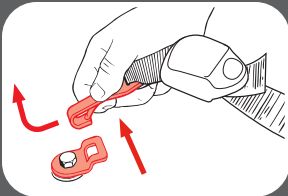

Press in on the hook's spring. Push tether hook in, then lift up and pull away from tether anchor.

## 9-B Choosing Vehicle Seat Location

*Review your vehicle owner's manual for Seating Locations*

***The best seating location for this car seat is one that:***

- Is recommended by your vehicle owner's manual, and
- Results in a secure installation of this car seat

In the event there is no available back seat and / or you have no other option than to place a child other than an infant in a rear-facing car seat in a front passenger seating position, the National Highway Traffic Safety Administration (NHTSA) recommends that you take the following steps:

- Ensure the child is properly restrained according to their age and size
- Move the seat as far back as possible
- Make sure the child is not leaning out of position, such as leaning forward into the deployment path of the air bag
- Set the air bag ON-OFF switch, if available, to the OFF position
- Move the seat as far back as possible



## 9-C Unsafe Vehicle Seat Location

Never install this car seat in any of the following vehicle seating locations:



rear-facing or side-facing vehicle seats



rear-facing with an active front air bag



booster mode with vehicle lap belt only seat belt

## 9-D Vehicle Seat Belts

*Review your vehicle owner's manual for vehicle seat belt use*

This car seat can be installed using a vehicle seat belt. To do this, you will need to change the seat belt to a locked mode for use with car seats. With some vehicle seat belts, this is done with the latchplate; with other vehicle seat belts, this is done with the retractor.

### *Vehicle Seat Belt Terms*

#### **Retractor**

A device that winds up the unused vehicle seat belt. It is often hidden inside the panels on the walls of the vehicle or in the vehicle seatback.

#### **Latch Plate**

The male end of the seat belt with the silver tongue.

#### **Seat Bight**

The crease where the vehicle seat back and seat bottom meet.

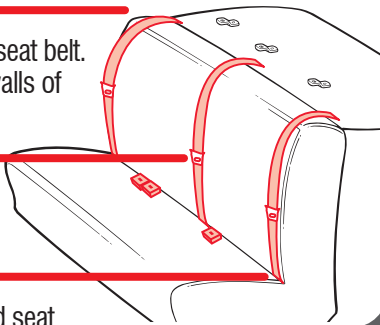

## Identify Your Seat Belt Type

There are two different types of vehicle seat belts that can be used with this car seat:

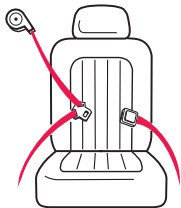

### Lap/Shoulder Belt

3 connection points. Can be used in all car seats modes of use.

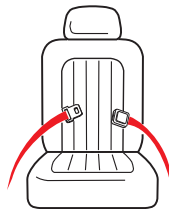

### Lap Belt Only

2 connection points. **Can ONLY be used in harness mode.**

The following types of vehicle seat belts **CANNOT** be used safely with this car seat:



Lap Belt with Motorized Shoulder Belt



Lap Belt or Shoulder Belt Mounted on Door

Belts Forward of the Seat Bight

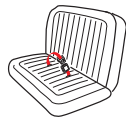

Some vehicles you may not get a secure fit. Read both your vehicle and car seat manuals.

## Lap/Shoulder Belt Installation - Rear-Facing/Forward Facing Modes

**Always review your vehicle owner's manual for specific information about your vehicle seat belts.**

There are three types of retractors: **ELR (Emergency Locking Retractor)**, **ALR (Automatic Locking Retractor)**, and **Switchable (ELR switch to ALR)**. To determine your type of retractor, follow these steps:

1. **Slowly** pull the belt out about halfway and stop.
2. Let the belt retract back several inches.
3. Try to **slowly** pull the belt out more. If the belt cannot be pulled any further, it is **ALR**. If it can be pulled further, go to the next step.
4. **Slowly** pull the belt all the way out, and then allow it to retract several inches.
5. Try to pull the belt all the way out again. If it cannot be pulled out, it is **Switchable**. If it can still be pulled out freely, it is **ELR**.

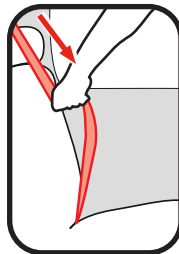

**Note:** Most vehicles manufactured after 1996 will have Switchable retractors in the back seat. If you have any questions about your retractor type, consult your vehicle owner's manual or call Graco for assistance.

## How to Lock Your Lap and Shoulder Vehicle Seat Belt

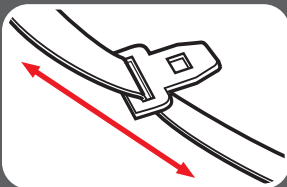

### Sliding Latch Plate and Switchable Retractor

A latchplate that slides freely on the belt webbing and cannot, by itself, hold the belt snug around a car seat.

When installing the car seat, route the vehicle seat belt through the proper belt path and buckle it in. **Slowly pull the shoulder belt all the way out to switch it to locking mode.** Then, as you pull the vehicle seat belt tight, feed all the slack back into the retractor.

Grab the sides of the seat at the belt path and slide the seat side-to-side and front-to-back. The seat should not move more than 1" (2.5 cm).

**Note:** When using the lock-off, you are not required to switch the retractor as an installation step. The lock-off locks the seat belt. However, it is recommended to switch the retractor after the installation is complete to avoid a possible strangulation risk.

- When using the Snuglock® lock-off, route the vehicle seat belt into the proper belt path under the lock-off and buckle. Push down firmly on the center of the seat while pulling on the shoulder belt to remove the slack. Do not pull on the strap with excessive force. Close the Snuglock® lock-off. Test for tightness. Slowly pull the shoulder belt all the way out to switch it to locking mode.



### ***Locking Latchplate and ELR Retractor***

A latchplate that holds the lap belt snug after it has been adjusted; contains a metal bar on the underside of the hardware that “locks” the belt in position.

When installing the car seat, route the vehicle seat belt through the proper belt path and buckle it in. Then, pull upwards on the shoulder belt so that the lap belt gets tight around the car seat.

Grab the sides of the seat at the belt path and slide the seat side-to-side and front-to-back. The seat should not move more than 1” (2.5 cm).

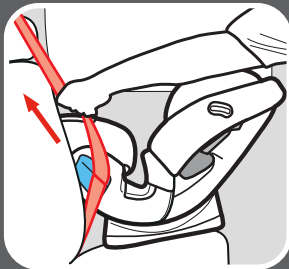
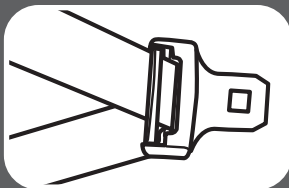

**9**  
**Additional  
Information**

## 9 Additional Information

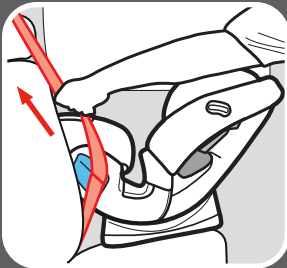
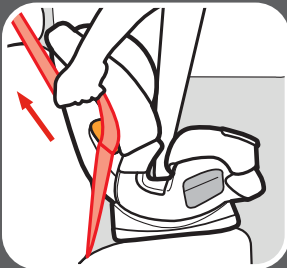
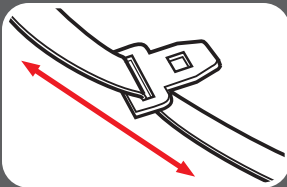

### ***Sliding Latch Plate and ALR Retractor***

A latchplate that slides freely on the belt webbing and cannot, by itself, hold the belt snug around a car seat.

#### **Slowly pull the shoulder belt all the way out.**

Route the vehicle seat belt through the proper belt path and buckle it in. Then, as you pull the vehicle seat belt tight, feed all the slack back into the retractor.

Grab the sides of the seat at the belt path and slide the seat side-to-side and front-to-back. The seat should not move more than 1" (2.5 cm).

## Sliding Latch Plate and ELR Retractor

A latchplate that slides freely on the belt webbing and cannot, by itself, hold the belt snug around a car seat.

With this retractor, you will need to use the locking clip to lock the vehicle seat belt.

To get a locking clip order online at [gracobaby.com](http://gracobaby.com) or call 1-800-345-4109

Route the vehicle seat belt through the proper belt path and buckle it in. Pull the vehicle seat belt tight. While pushing down on seat, pinch the two straps together behind the buckle tongue. Unbuckle the belt without allowing it to slip.

Attach locking clip to lap and shoulder belts as shown.

Rebuckle belt. Check that lap belt does not move by pulling hard. If belt loosens or lengthens, repeat procedure.

**Note:** When using the SnugLock® Lock-Off, you do not need to use the locking clip. The lock-off locks the seat belt.

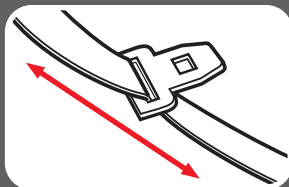

Locking Clip

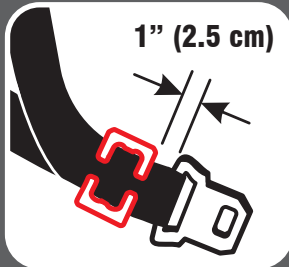

9  
Additional  
Information



## **Lap Belt Installation - DO NOT use in Booster Mode**

**Always review your vehicle owner's manual for specific information about your vehicle seat belts.**

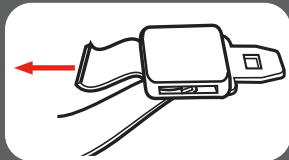

Grab the sides of the seat at the belt path and slide the seat side-to-side and front-to-back. The seat should not move more than 1" (2.5 cm).

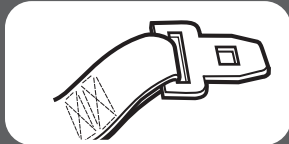

### **Locking Latch Plate and No Retractor**

When installing the car seat, route the lap seat belt through the proper path and buckle it in. Then, pull upwards on the tail of the belt so that the lap belt gets tight around the car seat.

### **Sewn On Latch Plate and ALR**

**Slowly pull the lap belt all the way out.** Route the vehicle seat lap belt through the proper belt path and buckle it in. Then, pull the lap belt tight while feeding all the slack back into the retractor.

## 9-E Aircraft Installation

This child restraint is certified for use in aircraft when using the harness system, and **ONLY** when not using the SnugLock® lock-off.

This child restraint is not certified for aircraft use when used as a booster seat because aircrafts do not have shoulder belts.

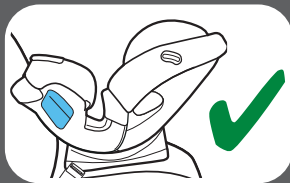

9  
Additional  
Information

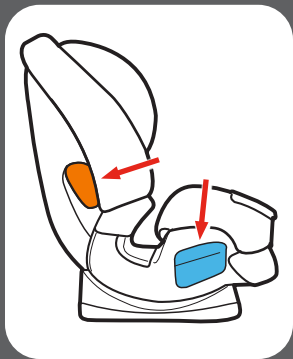

## 1. Move the Lower Anchor Attachment

**Rear-Facing:** If installing rear-facing, move the lower anchor attachment to the forward-facing belt path marked with an orange label.

**Forward-Facing:** If installing forward-facing, move the lower anchor attachment to the rear-facing belt path marked with a blue label.

See section 7 to move Lower Anchor attachment.

## 2. Route the Aircraft Seat Belt Over the SnugLock® Lock-off

Thread the aircraft seat belt through the belt path and out the other side. Buckle it. The seat belt should lie as flat as possible and not be twisted.

**Note:** It may be easier to route the aircraft seat belt by lifting seat pad up to expose the belt path.

**Rear-Facing:** Make sure the aircraft seat belt is **(A)** in front of the buckle strap when the buckle is in the inner-most position, and **(B)** in behind when in the outer-most position and that it is flat and is not twisted.

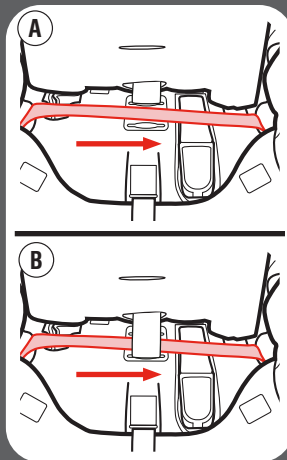

## 9 Additional Information

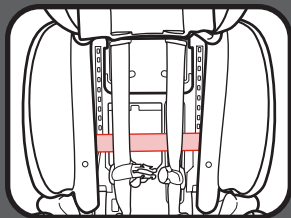

**Forward-Facing:** Make sure the aircraft seat belt is routed behind the harness strap, is flat, and is not twisted.

For complete rear-facing installation, see section 3-C, and for forward-facing installation, see section 4-C but do not use the tether.



## 10-A Cleaning Rapid Remove Seat Pad

Refer to seat pad care tag for washing instructions.

### **Headrest Pad**

Clean with a damp sponge using mild soap and cool water. If needed, pad may be removed for cleaning.

To remove, raise the headrest to the highest position.

Unhook the elastic loops from below the belt guides as shown.

Pull plastic tab out of the back of the headrest.

Untuck headrest pad from below the headrest actuator on the front of the headrest.

Remove the headrest pad.

Machine wash pad in cold water on delicate cycle and drip-dry. **DO NOT USE BLEACH.**

Reverse the steps to reattach the pad on the headrest.

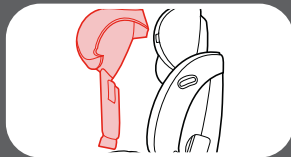
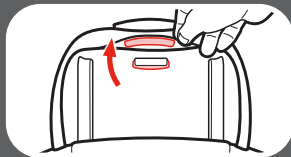
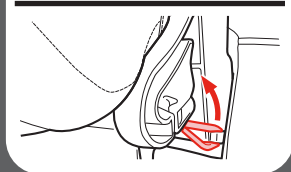
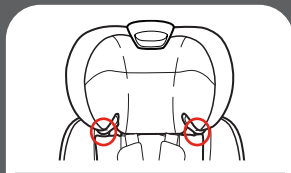

10  
Care &  
Cleaning

## 10 Care & Cleaning

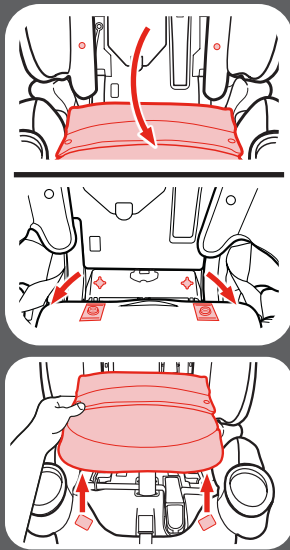

### **Seat Pad**

Clean with a damp sponge using mild soap and cool water. If needed, cover may be removed for cleaning.

To remove, unsnap snaps on the back and bottom of seat pad to expose the seat base.

Undo the seat pad from the fastening strips on both sides.

Machine wash pad in cold water on delicate cycle and drip-dry. **DO NOT USE BLEACH.**

Reverse the steps to reattach the pad to the shell.

## Front Seat Pad

Clean with a damp sponge using mild soap and cool water. If needed, pad may be removed for cleaning.

Pull plastic tabs out of armrests.

Undo the elastic straps in the rear-facing belt path.

Undo the 2 elastic straps by the recline handle.

Remove the front seat pad.

Machine wash pad in cold water on delicate cycle and drip-dry. **DO NOT USE BLEACH.**

Reverse the steps to reattach the pad to the shell.

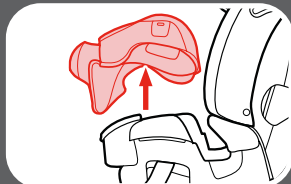
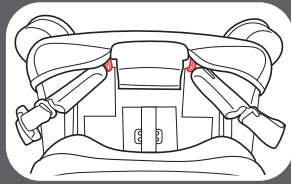
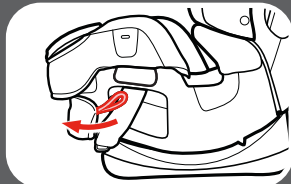
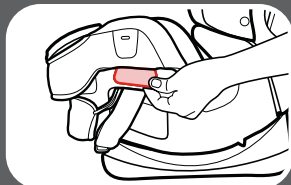

10 Care & Cleaning



## 10 Care & Cleaning

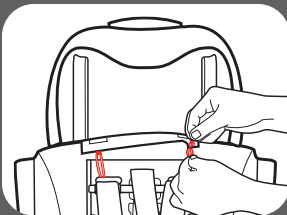
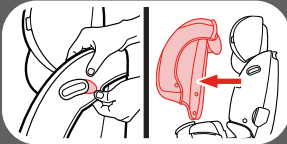
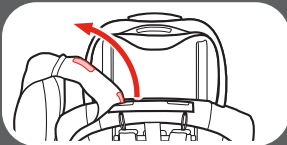

### **Side Pad**

Clean with a damp sponge using mild soap and cool water. If needed, pad may be removed for cleaning.

Undo snaps above the booster lap belt path on the sides of the seat.

Undo the fastening strips at the top of the seat.

To remove, pull the side pads from the shell.

Machine wash pad in cold water on delicate cycle and drip-dry. **DO NOT USE BLEACH.**

Reverse the steps to reattach the pad to the shell.

### **Top Pad**

Clean with a damp sponge using mild soap and cool water. If needed, pad may be removed for cleaning.

From the back of the seat, undo the 2 elastic straps and remove the pad from the shell.

Machine wash pad in cold water on delicate cycle and drip-dry. **DO NOT USE BLEACH.**

Reverse the steps to reattach the pad to the shell.

## 10-B Cleaning the Buckle

Recline the car seat and locate the metal retainer. Rotate the metal retainer up through the shell and pad. From the front, pull the buckle strap out.

To clean buckle, place in a cup of warm water and gently agitate the buckle. Press the red button several times while in the water.

**DO NOT SUBMERGE THE BUCKLE STRAP. DO NOT USE SOAPS, HOUSEHOLD DETERGENTS or LUBRICANTS.**

Shake out excess water and allow to air dry. Repeat steps as needed until it fastens with a click. Re-insert the buckle into the same slot it was removed. Pull up on buckle strap to make sure it is secured.

**WARNING!** Inspect and clean buckle from time to time to remove any objects or debris that could prevent latching.

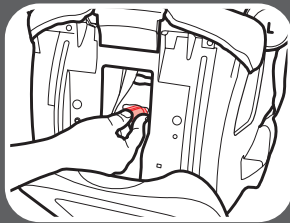
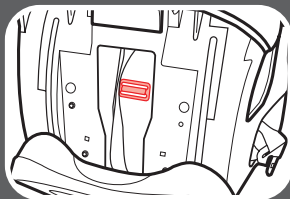

## 10-C Cleaning Harness, Lower Anchor Attachment and Tether

Surface wash only with mild soap and damp cloth. **DO NOT IMMERSE THE HARNESS STRAPS, LOWER ANCHOR STRAP, or TETHER STRAP IN WATER.** Doing so may weaken the straps.

If harness straps, lower anchor strap or tether strap are frayed or heavily soiled, contact Customer Service at [www.gracobaby.com](http://www.gracobaby.com) or 1-800-345-4109.



**Notes:**

## Replacement Parts

To purchase parts or accessories in the United States,  
please contact us at the following:

**[www.gracobaby.com](http://www.gracobaby.com)**

or

**1-800-345-4109**

---



Store instruction manual in the  
slot with the instruction book  
icon as shown.

