

NWL0001437534B

9/22



SNUGRIDE® SNUGLOCK®

INFANT CAR SEAT BASE FEATURING LOAD LEG TECHNOLOGY

Read This Instruction Manual

Do not install or use this child restraint until you read and understand the instructions in this manual.

FAILURE TO PROPERLY USE THIS CHILD RESTRAINT INCREASES THE RISK OF SERIOUS INJURY OR DEATH IN A SUDDEN STOP OR CRASH.

KEEP INSTRUCTIONS FOR FUTURE USE.

www.gracobaby.com

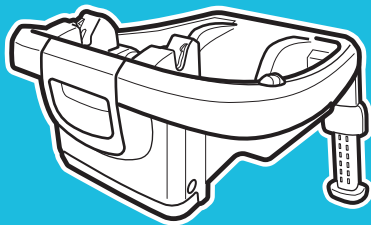

Important

Pages 4-11

- 1-A Quick Guide to Your Manual**
- 1-B Before You Begin**
- 1-C Safety Warnings**

Features

Pages 12-19

- 2-A Car seat base Features**
- 2-B Remove Car Seat from Base**
- 2-C Attach Car Seat to Base**
- 2-D Recline the Base**
- 2-E Using the Load Leg**
- 2-F Choosing Vehicle Seat Location**
- 2-G Choosing Lower Anchor Attachment or Seat Belt**
- 2-H What Is Lower Anchor Attachment**

Rear-Facing Use

Pages 20-38

- 3-A Rear-Facing Checklist**
- 3-B Install With Base With Lower Anchor Attachment**
- 3-C Install With Base With Vehicle Seat Belt**

Vehicle Information

Pages 39-50

- 4-A Additional Lower Anchor Attachment Information**
- 4-B How to Remove Lower Anchor Attachment**
- 4-C Unsafe Vehicle Seats**
- 4-D Vehicle Seat Belts**

Care & Cleaning

Page 51

- 5-A Cleaning Harness and Lower Anchor Attachment**



1 Important

1-A Quick Guide to Your Manual

This base is compatible with any Graco® Click Connect™ car seat.

Get to Know Your Car Seat

Review section 2-A to see all of the features of this infant car seat.

What Seating Location Should I Use?

The best seating location for this infant car seat is one that:

- Is recommended by your vehicle owner's manual, and
- Results in a secure installation of this car seat.



Never place a child rear-facing in a seating position with an active front air bag.

Review section 4 of this manual AND your vehicle owner's manual.

Which Installation Method Should I Use?

This infant car seat base can be installed in your vehicle using either the vehicle seat belt **OR** the lower anchor attachment system. Both are equally safe to use. **DO NOT USE BOTH AT THE SAME TIME.**

When Installing Base

Lower Anchor Attachment System



Lower anchor attachment consists of lower anchors, which are built-in to your vehicle, and connecting hooks that are built-in your car seat.

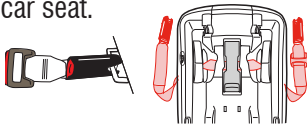

Review section 3-B of this manual AND your vehicle owner's manual.

Vehicle Seat Belt



There are two types of vehicle seat belts that can be used. Lap/Shoulder Seat Belt or Lap Only Seat Belt.

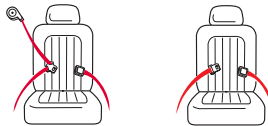

Review section 3-C of this manual AND your vehicle owner's manual.



1 Important



1 Important

1-B Before You Begin

Your child's safety depends on you. No car seat can guarantee protection from injury in every situation, but proper use helps reduce the risk of serious injury or death.

Even if this car seat seems easy to figure out on your own, you must follow the detailed instructions in this instruction manual to ensure the steps below are performed correctly.

Register This Child Restraint

Please fill out the prepaid registration postcard attached to the harness and mail it in today **or register online at www.gracobaby.com/carseatregistration**.

Child restraints could be recalled for safety reasons. You must register this restraint to be reached in a recall. Send your name, address, and the restraint's model number and manufacturing date to:

Graco Children's Products, Inc.

Attn: Customer Service

P.O. Box 169, Elverson, PA 19520-9901

or call 1-800-345-4109

or register online at

www.gracobaby.com/carseatregistration

For recall information, call the U.S. Government's Vehicle Safety Hotline at 1-888-327-4236 (TTY: 1-800-424-9153), or go to <http://www.NHTSA.gov>.

For future reference or if you change addresses, record the model name, model number, date of manufacture, and purchase date of this car seat below. You can find this information either on the registration card if you still have it or on the date label located on the back of the car seat.

Model Name _____

Model Number _____

Date of Manufacture _____

Date of Purchase _____

If You Need Help

In the U.S.A, please contact our Customer Service Department with any questions you may have concerning parts, use, or maintenance. When you contact us, please have your product's model number and date of manufacture ready so that we may help you efficiently. These numbers can be found on a sticker on the back side of your car seat.

For additional resources or to get your car seat checked by a child passenger safety technician, please visit the following web sites:

www.nhtsa.gov • www.seatcheck.org • www.safekids.org



1 Important

Certification

This child restraint meets or exceeds all applicable requirements of Federal motor vehicle safety standard 213 for use in motor vehicles.



This child restraint's **base** is NOT certified for use in aircraft.

Contact the airline for their specific policies.

Car Seat's Useful Life

STOP using this car seat and throw it away 7 years after the date of manufacture. Look for date of manufacture label on back of the car seat.

Graco Children's Products Inc. advises against loaning or passing along a car seat unless you know the complete history of the product. We also advise against purchasing a car seat second hand.

Vehicle Seat Protection

Protect vehicle seat. Use a car seat mat, towel, or thin blanket under and behind car seat.

1-C Safety Warnings



1 Important

No car seat can guarantee protection from injury in every situation, but proper use helps reduce the risk of serious injury or death. **READ THIS MANUAL CAREFULLY.**

⚠ WARNING!

Failure to follow these instructions and child restraint's labels can result in child striking the vehicle's interior during a sudden stop or crash.



! NEVER PLACE THIS CHILD RESTRAINT REAR-FACING IN A VEHICLE SEATING LOCATION THAT HAS AN ACTIVE FRONT AIR BAG.

If an air bag inflates, it can hit the child and car seat with great force and cause serious injury or death to your child.

! Review your vehicle owner's manual for more information about air bags and car seat use.

! If your vehicle does not have a back seat, review your vehicle owner's manual.

! Children are safer riding rear-facing and should ride rear-facing as long as possible, until they reach the maximum rear-facing height or weight rating for their car seat. Graco convertible and all-in-one car seats have higher rear-facing limits that will allow children to ride rear-facing longer after outgrowing their infant car seat. Be sure to check your local and state laws, as well as AAP and NHTSA recommendations, for car seat usage.*

! This child restraint must only be used with children weighing between 4-35 lb (1.8-16 kg).

! Select a suitable location for the car seat in your vehicle.

! Secure car seat with a vehicle seat belt or lower anchor attachment that is properly routed as shown in this manual.

! Vehicle seat belt system MUST hold car seat securely. Not all vehicle seat belts can be used with a car seat.

! If vehicle seat belt does not hold car seat securely, read “Vehicle Seat Belts” section 4-D and your vehicle owner’s manual.

! Always secure car seat with lower anchor attachment or a vehicle seat belt, even when unoccupied. In a crash, an unsecured car seat can injure passengers.

*Graco Supports the American Academy of Pediatrics and National Highway Traffic Safety Administration’s Car Seat Guidelines. Visit www.gracobaby.com/en-US/safety for information on car seat usage recommendations.



1 Important

! DO NOT use car seat if it is damaged or missing parts.

! If car seat is in a crash, it must be replaced. DO NOT use it again! A crash can cause unseen damage and using it again could result in serious injury or death.

! DO NOT use accessories or parts other than those provided by Graco except for a thin towel or mat to protect your vehicle seat or rolled towels or pool noodles to help get your car seat level. Their use could alter the performance of the car seat.

! DO NOT remove lower anchor attachment system from car seat. If using vehicle seat belt to secure car seat, lower anchor attachment connectors must be stored.

! Never leave child unattended, even when sleeping. Child may become tangled in harness straps and suffocate or strangle.

! Rear-facing car seat must be properly leveled:

- Too reclined can result in injury or ejection.
- Too upright can result in breathing difficulties.



! Never attach two lower anchor attachment connectors to one vehicle lower anchor point unless specifically allowed by the vehicle manufacturer.

! Do not use both the vehicle seat belt and lower anchor attachment strap at the same time when using the car seat rear-facing.

2-A Car seat base Features

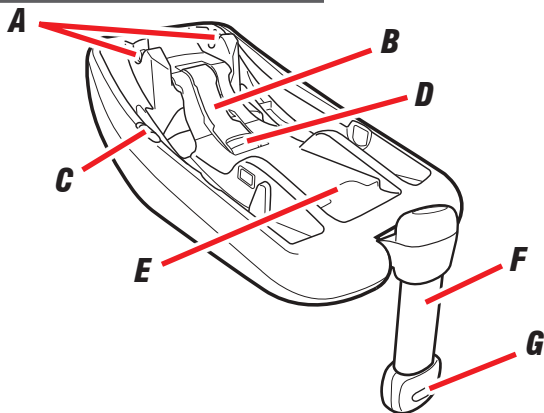

- A** Car Seat Base Lock
- B** SnugLock® Lock-Off
- C** Level Indicator
- D** SnugLock® Lock-Off Release Lever
- E** Instruction Manual Storage
- F** Load Leg
- G** Extension Button
- H** Base Recline Lever
- I** Base Recline Foot
- J** Lower Anchor Attachment Storage

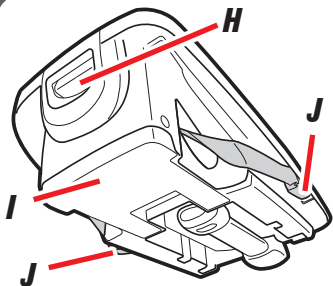

2-B Remove Car Seat from Base

To Remove Car Seat from Base

From the back of the car seat, squeeze the base release handle and lift the car seat out of the base.

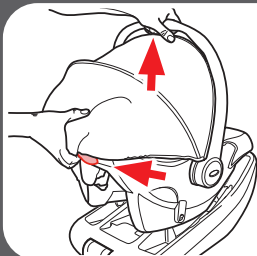

2-C Attach Car Seat to Base

Attaching Car Seat To Base

Align the locking bar at the front of the car seat with the locks in the base. Set car seat in the base. Push down on the front of the car seat. You will hear a “click” when it is locked.

Pull up on the front corners of the seat to make sure it is locked.

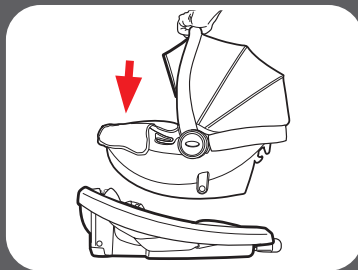
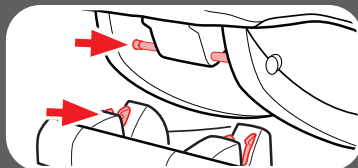

2-D Recline the Base

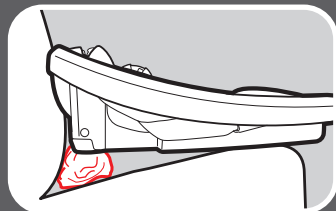

Base Has 4 Recline Positions

Squeeze the base recline lever and lift the base to extend the foot.

Squeeze the base recline lever and lower the base to retract the foot.

Check the level indicator for appropriate install.

(See Next Page)

When the foot is completely extended and the level indicator is not correct for your child's age, you may raise the foot and place a rolled towel under the foot until the indicator shows correctly.

When Reading The Level Indicator

Vehicle **MUST** be on level ground.

Use corrected age for preemies.

- If the blue indicator is in the clear area, the restraint is level for infants 0+ months in age.

- If blue indicator is partially in the notched area, the restraint is level for a child 3+ months in age.

- If any blue appears outside the black lines, the child restraint is **NOT** level. You must adjust your recline position.

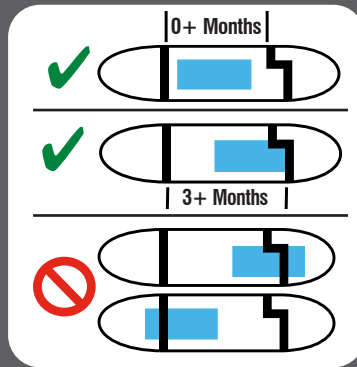

2 Features

2-E Using the Load Leg

!WARNING!

The Load Leg provides additional stability in the event of a collision.

DO NOT place the load leg on a storage door compartment or the vehicle floor if the vehicle manufacturer warns against it. Some vehicle manufacturers do not allow the use of load legs in all seating positions. Review your vehicle owner's manual to make sure load legs can be used with your vehicle.

DO NOT allow children to play with the load leg.

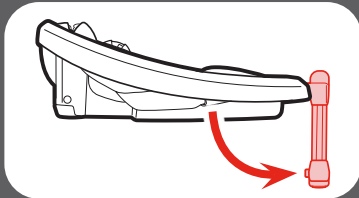
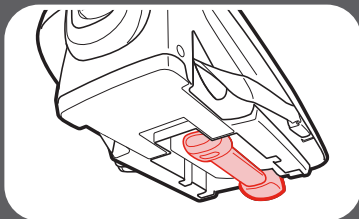

Unfold the Load Leg

From the bottom of the base, pull on the load leg to release and rotate it down.

Keep hands away from the pivot point of the load leg when folding.

Extend the Load Leg

Extend the Load Leg by pressing the extension button **(A)** and pulling down on the leg until the load leg contacts the vehicle floor.

The foot of the Load Leg must be extended in a **LOCKED** position with **FIRM** contact the vehicle floor.

The foot of the Load Leg **MUST NOT** raise the base off the vehicle seat.

Make sure the leg is rotated fully forward until it stops.

To store the load leg, press the extension button **(A)** and retract the foot to its shortest length. Then fold the Load Leg back into the base. The Load Leg is securely stored when it “clicks” into place.

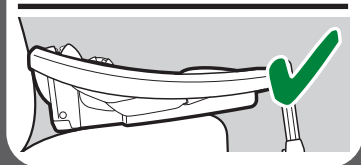
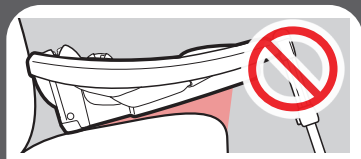
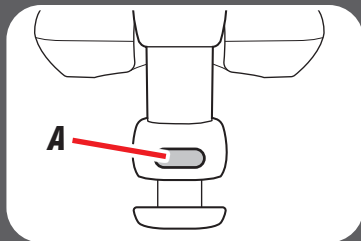

2-F Choosing Vehicle Seat Location

Review your vehicle owner's manual for seating locations. Review section 4 for additional information.

Some vehicles have specific requirements for where the car seat can be installed. Be sure to check your vehicle owner's manual for all available seating positions.

According to accident statistics, children are safer when properly restrained in the rear seating positions than in the front seating positions. The center of the back seat can be the safest during a possible side impact.



⚠️ WARNING!



NEVER place this child restraint rear-facing in a vehicle seating location that has an active front air bag.

In the event there is no back seat, review your vehicle owner's manual to see how to use your infant child restraint.

2-G Choosing Lower Anchor Attachment or Seat Belt

This car seat can be installed in your vehicle using either the vehicle seat belt OR the lower anchor attachment system. Both systems are equally safe to use. DO NOT USE BOTH AT THE SAME TIME. Review section 4 for additional information.

2-H What is Lower Anchor Attachment?

Lower anchor attachment consists of lower anchors, which are built-in to your vehicle, and connecting hooks that are built-in to your car seat. Lower anchors are used INSTEAD of the vehicle's seat belt to secure the child seat to the vehicle.

Review your vehicle's owner manual for exact location and use. Review section 4 for additional information.

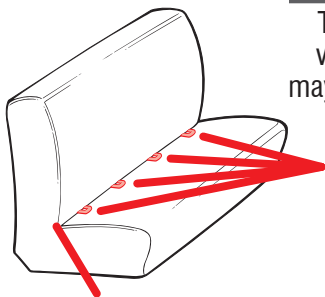

Vehicle Seat Crease

Typical seat in a passenger vehicle. Other vehicle types may have different lower anchor attachment locations.

Vehicle Lower Anchor

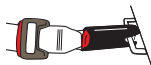

3-A Rear-Facing Checklist

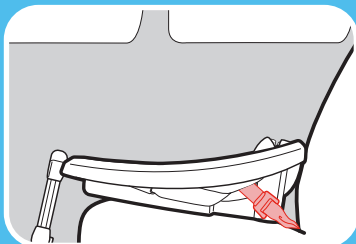

Lower Anchor Attachment Strap

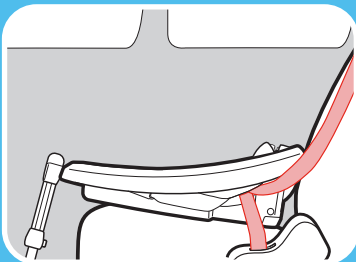

Vehicle Lap/Shoulder Seat Belt

Rear-Facing:

- Car seat **MUST** be rear-facing in the vehicle back seat.
- Make sure lower anchor attachment strap or vehicle seat belt is routed through the rear-facing belt path, marked with a blue label.
- Install this car seat tightly in your vehicle. Car seat **should not move** at the belt path more than 1" (2.5 cm) from side to side and front to back.
- Make sure to check the level indicator or level line for proper recline.
- The foot of the Load Leg **MUST** securely contact the vehicle floor.



3 Rear Facing

Children are safer riding rear-facing and should ride rear-facing as long as possible, until they reach the maximum rear-facing height or weight rating for their car seat. Graco convertible and all-in-one car seats have higher rear-facing limits that will allow children to ride rear-facing longer after outgrowing their infant car seat. Be sure to check your local and state laws, as well as AAP and NHTSA recommendations, for car seat usage.

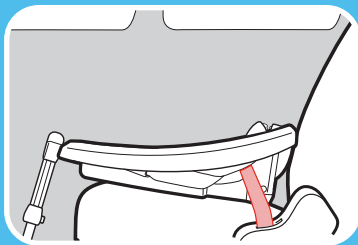

Vehicle Lap Only Seat Belt

⚠️ WARNING!

 **NEVER place this child restraint rear-facing in a vehicle seating location that has an active front air bag.**



3 Rear Facing

3-B Install With Base With Lower Anchor Attachment

Review your vehicle owner's manual for lower anchor attachment location and use.

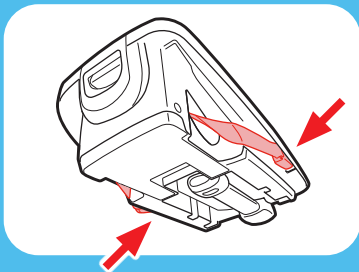

1. Remove Lower Anchor Attachment Connectors from Storage Location

Unhook the lower anchor attachment connectors and remove from storage position.

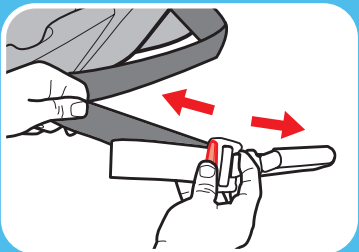

2. Extend the Lower Anchor Attachment Strap

Extend the lower anchor attachment strap to its maximum length by pressing the gray button and pulling on the strap.

3. Unfold the Load Leg

From the bottom of the base, pull on the load leg to release and rotate it down.

Keep hands away from the pivot point of the load leg when folding.

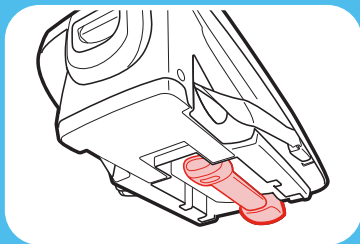

4. Place Base in Back Seat of the Vehicle

Place the base flat on the vehicle seat. Push it back until the front of the base touches the vehicle seat back. Center the base between the lower Lower anchor attachment anchors.

If allowed by your Vehicle Owners Manual, the center seating position may be used if the anchor spacing is 11" (28 cm) or greater.

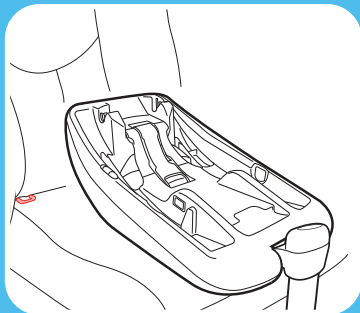
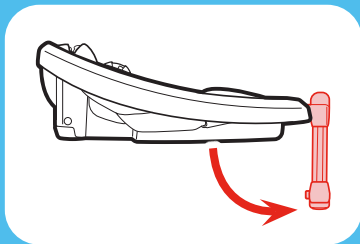

3 Rear Facing

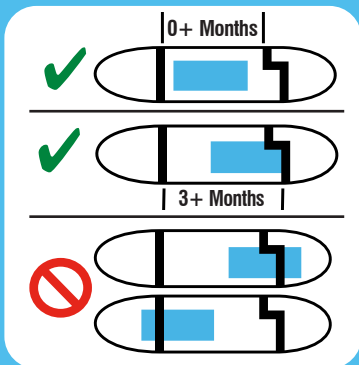
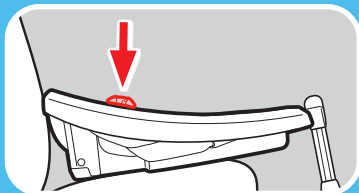

5. Check the Level Indicator

Vehicle **MUST** be on level ground.

To recline, review section 2-D.

6. Open the SnugLock® Lock-Off

Push in the release lever and open the lock-off.

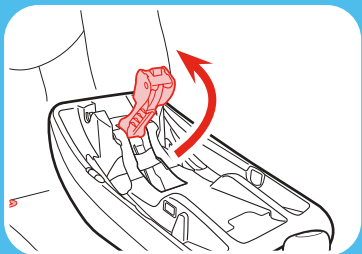
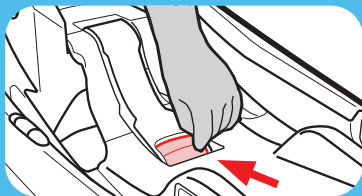

7. Connect Lower Anchor Attachment Connectors to Vehicle's Lower Anchor Attachment Anchors

Lower anchor attachment strap should lay as flat as possible and not be twisted.

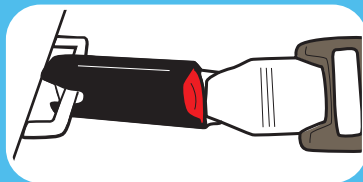

**3 Rear
Facing**

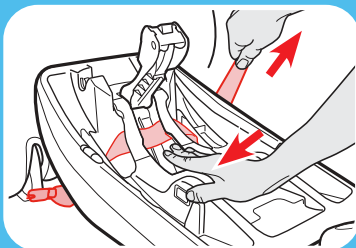

8. Remove the Slack

Press down firmly on the top of the base while pulling on the free end of the lower anchor attachment strap to remove all the slack.

Do not pull on the belt with excessive force. If the belt is too tight, you will not be able to close the SnugLock® Lock-Off.

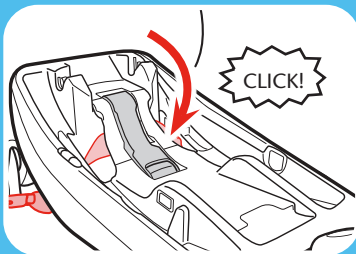

9. Close the SnugLock® Lock-Off

Shut the lock-off on top of the lower anchor attachment strap.

Close the lock-off until you hear a "Click".



3 Rear Facing

! WARNING!

Keep hands away from the lock-off area when closing the lock-off.

10. Test For Tightness

Grab the sides of the base at the belt path, push and pull the base from side to side and front to back.

If the base moves less than 1" (2.5 cm), it is tight enough.

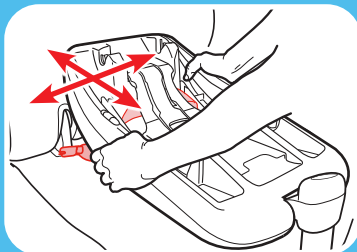

11. Extend the Load Leg

Extend the Load Leg by pressing the extension button (A) and pulling down on the leg until the load leg contacts the vehicle floor.

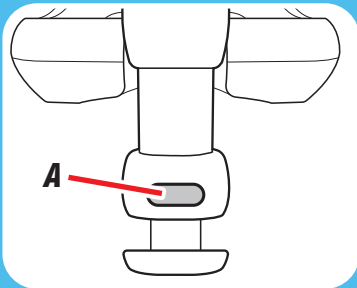

The foot of the Load Leg must be extended in a **LOCKED** position with **FIRM** contact the vehicle floor.

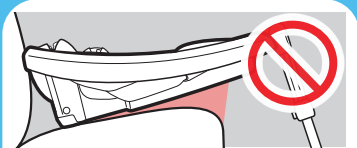

The foot of the Load Leg **MUST NOT** raise the base off the vehicle seat.

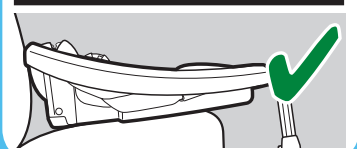



**3 Rear
Facing**

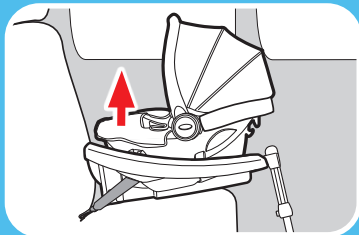
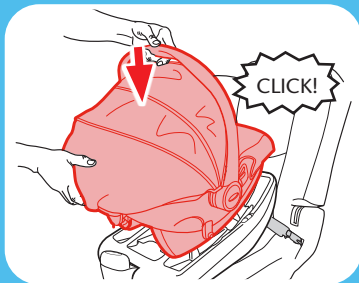

12. Attach Car Seat to Base

Place car seat into the base. Push down on the front of the car seat and handle until you hear a “click”.

Test to make sure the car seat is attached by pulling up on the front corners of car seat.

13. Check the Level Indicator

Vehicle **MUST** on level ground.

Check the level indicator with child in the child restraint.

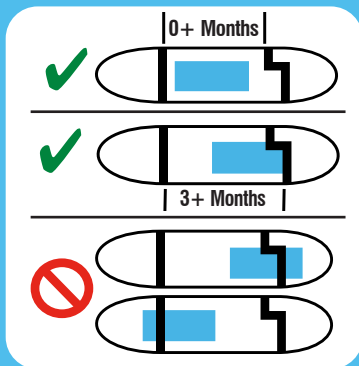
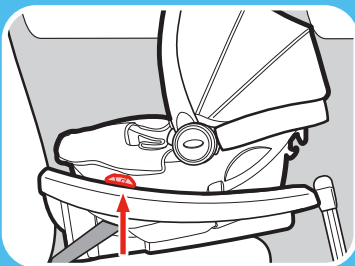

3 Rear
Facing

Is Everything Correct?

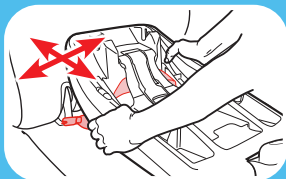

**Base Does Not Move
More Than 1" (2.5 cm)
At The Belt Path**

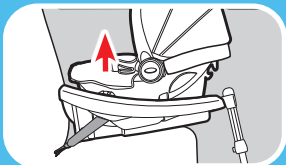

**Car Seat Is Properly
Attached To Base**

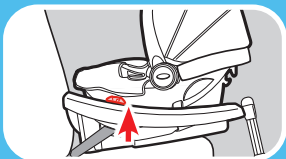

**With Vehicle On Level
Ground, Check the
Level Indicator**



**3 Rear
Facing**

3-C Install With Base With Vehicle Seat Belt

1. Store Lower Anchor Attachment Connectors

Extend the lower anchor attachment strap to its maximum length and attach the lower anchor attachment connectors to the plastic bars on sides of base as shown.

Do NOT tighten the strap. If the strap is tightened, you will not be able to close the SnugLock® Lock-Off.

2. Unfold the Load Leg

From the bottom of the base, pull on the load leg to release and rotate it down.

Keep hands away from the pivot point of the load leg when folding.

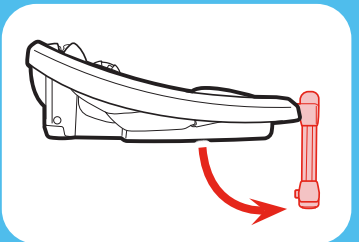
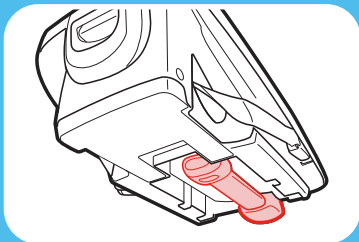
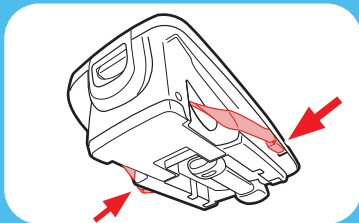

3 Rear Facing

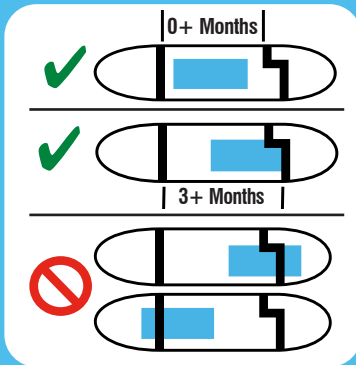
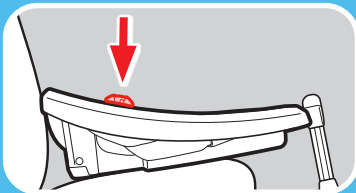
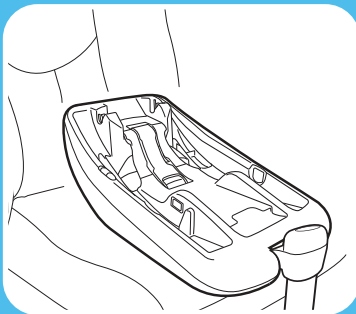

3. Place Base in Back Seat of the Vehicle

Place the base flat on the vehicle seat. Push it back until the front of the base touches the vehicle seat back.

4. Check the Level Indicator

Vehicle **MUST** be on level ground.

To recline, review section 2-D.

5. **Open the SnugLock® Lock-Off**

Push in the release lever and open the lock-off.

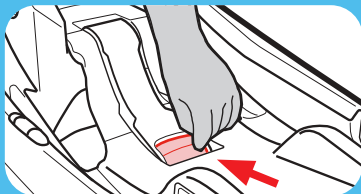

6. **Route the Vehicle Seat Belt**

Thread the lap portion of the vehicle seat belt through the rear-facing belt path (marked with a blue label) and buckle it. The seat belt should lay as flat as possible and not be twisted.

Note: DO NOT tangle the vehicle seat belt with the lower anchor strap.

Make sure the belt is threaded above the notches near the SnugLock® Lock-Off.

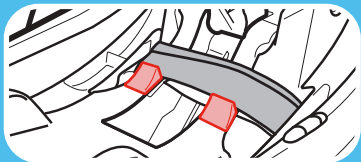
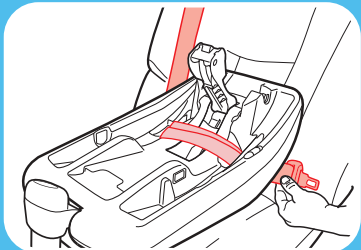
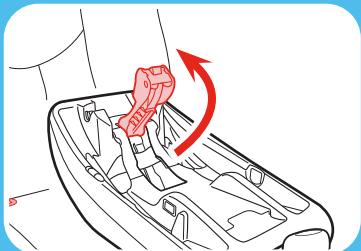

Review your vehicle's owner's manual for vehicle seat belt use

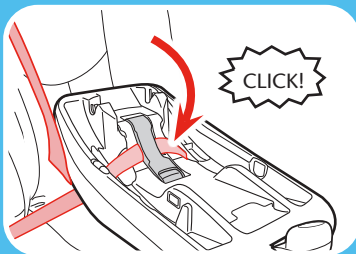

7. Tighten the Vehicle Seat Belt

Press down firmly on the top of the base while pulling on the shoulder belt to remove the slack.

Do not pull on the belt with excessive force. If the belt is too tight, you will not be able to close the SnugLock® Lock-Off.

8. Close the SnugLock® Lock-Off

Shut the lock-off on top of the vehicle seat belt.

Close the lock-off until you hear a “Click”.



3 Rear Facing

⚠ WARNING!

Keep hands away from the lock-off area when closing the lock-off.

9. Test For Tightness

Grab the sides of the base where the seat belt is and push and pull the base from side to side and front to back.

If the base moves less than 1" (2.5 cm), it is tight enough.

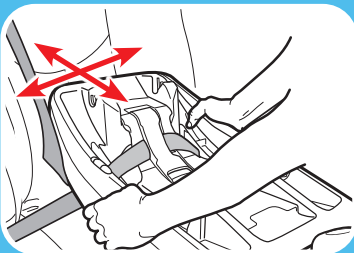

10. Extend the Load Leg

Extend the Load Leg by pressing the extension button (A) and pulling down on the leg until the load leg contacts the vehicle floor.

The foot of the Load Leg must be extended in a **LOCKED** position with **FIRM** contact the vehicle floor.

The foot of the Load Leg **MUST NOT** raise the base off the vehicle seat.

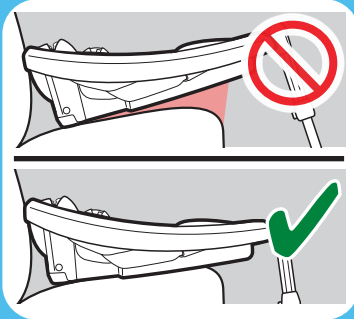
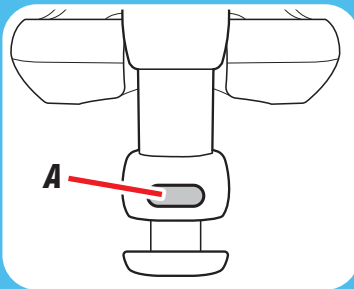

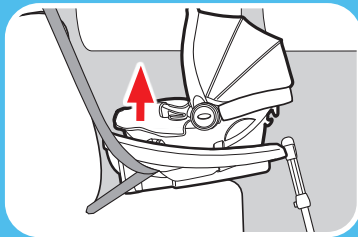
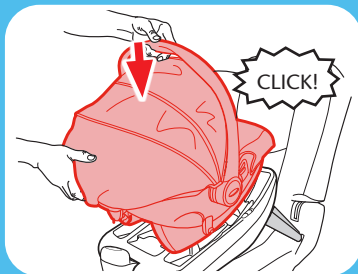

11. Attach Car Seat to Base

Place car seat into the base. Push down on the front of the car seat and handle until you hear a “click”.

Test to make sure the car seat is attached by pulling up on the front corners of car seat.

12. Check the Level Indicator

Vehicle **MUST** be on level ground.

Check the level indicator with child in the child restraint.

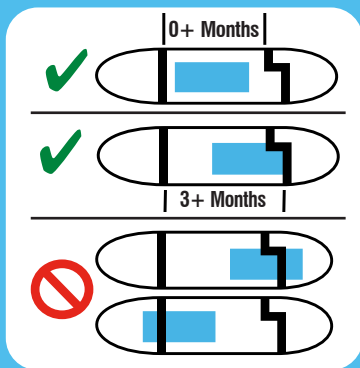
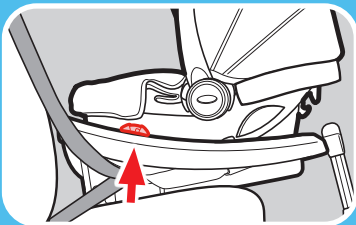

3 Rear
Facing

Is Everything Correct?

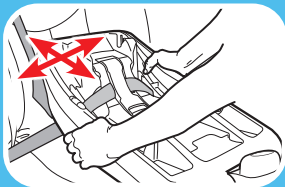

**Base Does Not Move
More Than 1" (2.5 cm)
At The Belt Path**

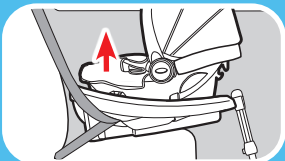

**Car Seat Is Properly
Attached To Base**

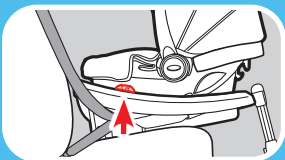

**With Vehicle On Level
Ground, Check the
Level Indicator**



**3 Rear
Facing**

4-A Additional Lower Anchor Attachment Information

This car seat can be installed in your vehicle using either the vehicle seat belt OR the lower anchor attachment system. Both systems are equally safe to use. **DO NOT USE BOTH AT THE SAME TIME.**

The lower anchor attachment system allows you to securely attach your car seat in your car without using the vehicle seat belt and possibly to get a better fit. All 2003 and newer model year vehicles are required to have a lower anchor attachment system, although some manufacturers began including lower anchor attachment earlier. Some vehicle owner manuals use the term ISOFIX to identify the lower anchor attachment system.

Only use lower anchor attachment in seating positions recommended by your vehicle manufacturer. Review your vehicle owner's manual for more information.

4-B How to Remove Lower Anchor Attachment

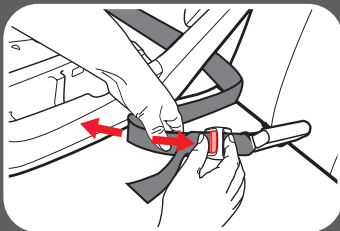

1. Push Gray Button In While Pulling on Lower Anchor Attachment Strap to Loosen

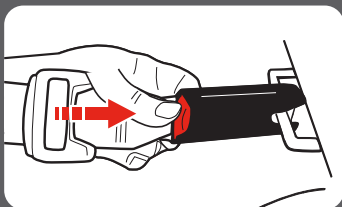

2. Press and Hold Lower Anchor Attachment Release Button

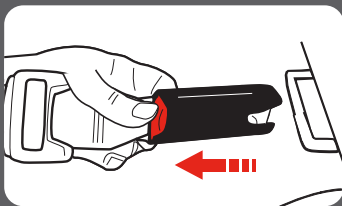

3. Pull Away From Anchor Point

4-C Unsafe Vehicle Seats

Never install this car seat in side-facing or rear-facing vehicle seats.

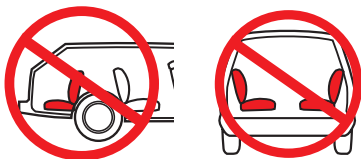

4-D Vehicle Seat Belts

Review your vehicle owner's manual for vehicle seat belt use

This car seat can be installed using a vehicle seat belt. To do this, you will need to change the seat belt to a locked mode for use with car seats. With some vehicle seat belts, this is done with the latch plate; with other vehicle seat belts, this is done with the retractor.

Vehicle Seat Belt Terms

Retractor

A device that winds up the unused vehicle seat belt. It is often hidden inside the panels on the walls of the vehicle or in the vehicle seat back.

Latch Plate

The male end of the seat belt with the silver tongue.

Seat Crease

The crease where the vehicle seat back and seat bottom meet.

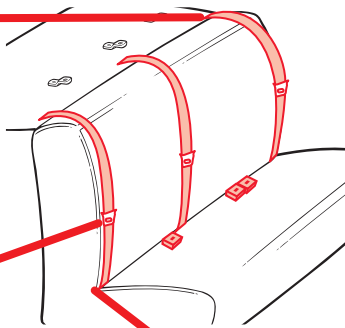

Identify Your Seat Belt Type

There are two different types of vehicle seat belts that can be used with this car seat:



Lap/Shoulder Seat Belt

3 connection points.

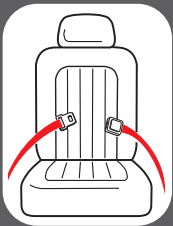

Lap Only Seat Belt

2 connection points.

The following types of vehicle seat belts **CANNOT** be used safely with this car seat:



Lap Belt with Motorized
Shoulder Belt



Lap Belt or Shoulder
Belt Mounted on Door

Belts Forward of the Seat Crease

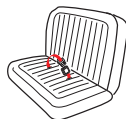

Some vehicles you may not get a secure fit. Read both your vehicle and car seat manuals.

Lap/Shoulder Seat Belt Installation

Always review your vehicle owner's manual for specific information about your vehicle seat belts.

There are three types of retractors: **ELR (Emergency Locking Retractor)**, **ALR (Automatic Locking Retractor)**, and **Switchable (ELR switch to ALR)**. To determine your type of retractor, follow these steps:

1. **Slowly** pull the belt out about halfway and stop.

2. Let the belt retract back several inches.

3. Try to **slowly** pull the belt out more. If the belt cannot be pulled any further, it is **ALR**, ready to install your car seat. If it can be pulled further, go to the next step.

4. **Slowly** pull the belt **all the way out**, and then allow it to retract several inches. You may hear some clicking sounds.

5. Try to pull the belt all the way out again. If it cannot be pulled out, it is **Switchable**, ready to install your car seat. If it can still be pulled out freely, it is **ELR**. Review the following pages to properly install your infant car seat.

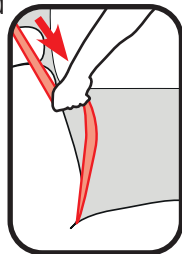

Note: Most vehicles manufactured after 1996 will have Switchable retractors in the back seat. If you have any questions about your retractor type, consult your vehicle owner's manual or call Graco for assistance.

How to Lock Your Lap/Shoulder Vehicle Seat Belt

Sliding Latch Plate and Switchable Retractor

A latch plate that slides freely on the belt webbing and cannot, by itself, hold the belt snug around a car seat.

When installing the car seat, route the vehicle seat belt through the proper belt path and buckle it in. **Slowly pull the shoulder belt all the way out to switch it to locking mode.** Then, as you pull the vehicle seat belt tight, feed all the slack back into the retractor.

Grab the sides of the base or seat at the belt path and slide side to side and front to back. The base or seat should not move more than 1" (2.5 cm).

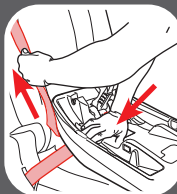
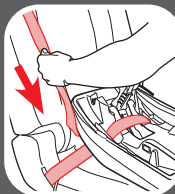
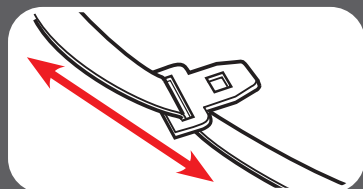

Note: With the vehicle seat belt in this locking mode, all the tension is upwards in the shoulder belt. This may start to tilt your car seat sideways when rear-facing. If this happens, use a locking clip instead of switching the retractor. See Sliding Latch Plate and ELR Retractor.

Note: When using the lock-off, you are not required to switch the retractor as an installation step. The lock-off locks the seat belt. However, it is recommended to switch the retractor after the installation is complete to avoid a possible strangulation risk.

- When using the Snuglock® lock-off, route the vehicle seat belt into the proper belt path under the lock-off and buckle. Push down firmly on the center of the seat while pulling on the shoulder belt to remove the slack. Do not pull on the strap with excessive force. Close the Snuglock® lock-off. Test for tightness. Slowly pull the shoulder belt all the way out to switch it to locking mode.

Locking Latch Plate and ELR Retractor

A latch plate that holds the lap belt snug after it has been adjusted; contains a metal bar on the underside of the hardware that “locks” the belt in position.

When installing the car seat, route the vehicle seat belt through the proper belt path and buckle it in. Then, pull upwards on the shoulder belt so that the lap belt gets tight around the base or car seat.

Grab the sides of the base or seat at the belt path and slide side to side and front to back. The base or seat should not move more than 1” (2.5 cm).

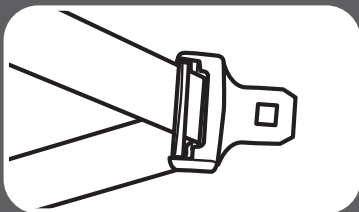

Note: When using the base, remove all the slack from the seat belt. The lock-off locks the seat belt.

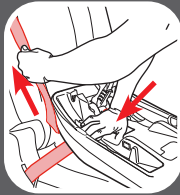
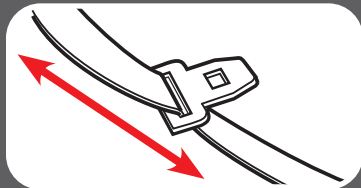

Sliding Latch Plate and ALR Retractor

A latch plate that slides freely on the belt webbing and cannot, by itself, hold the belt snug around a car seat.

Slowly pull the shoulder belt all the way out. Route the vehicle seat belt through the proper belt path and buckle it in. Then, as you pull the vehicle seat belt tight, feed all the slack back into the retractor.

Grab the sides of the base or seat at the belt path and slide side-to-side and front-to-back. The base or seat should not move more than 1" (2.5 cm).

Sliding Latch Plate and ELR Retractor

A latch plate that slides freely on the belt webbing and cannot, by itself, hold the belt snug around a car seat.

With this retractor, you will need to use the locking clip to lock the vehicle seat belt.

To obtain a locking clip call 1-800-345-4109.

Route the vehicle seat belt through the proper belt path and buckle it in. Pull the vehicle seat belt tight. While pushing down on seat, pinch the two straps together behind the buckle tongue. Unbuckle the belt without allowing it to slip.

Attach locking clip to lap and shoulder belts as shown.

Buckle belt. Check that lap belt does not move by pulling hard. If belt loosens or lengthens, repeat procedure.

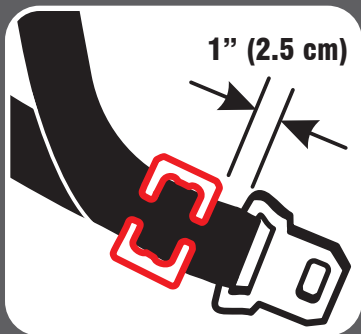
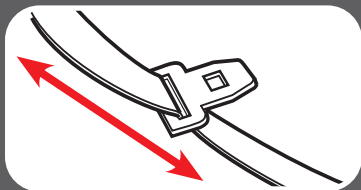

Lap Belt Installation

Always review your vehicle owner's manual for specific information about your vehicle seat belts.

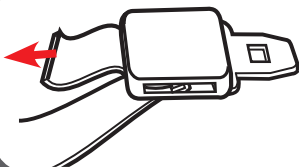

Grab the sides of the seat at the belt path and slide side to side and front to back. The base or seat should not move more than 1" (2.5 cm).

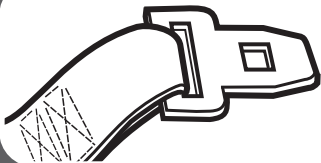

Grab the sides of the seat at the belt path and slide side to side and front to back. The base or seat should not move more than 1" (2.5 cm).

Locking Latch Plate and No Retractor

When installing the car seat, route the lap seat belt through the proper path and buckle it in.

Then, pull upwards on the tail of the belt so that the lap belt gets tight around the car seat.

Sewn On Latch Plate and ALR Retractor

Slowly pull the lap belt all the way out. Route the vehicle seat lap belt through the proper belt path and buckle it in. Then, pull the lap belt tight while feeding all the slack back into the retractor.

5-A Cleaning Harness and Lower Anchor Attachment

Surface wash only with mild soap and damp cloth. **DO NOT IMMERSE THE HARNESS STRAPS or LOWER ANCHOR ATTACHMENT STRAP IN WATER.** Doing so may weaken the straps.

If harness straps or lower anchor attachment strap are frayed or heavily soiled, contact Customer Service at www.gracobaby.com or 1-800-345-4109.

5 Care
& Cleaning

Replacement Parts

To purchase parts or accessories in the United States,
please contact us at the following:

www.gracobaby.com

or

1-800-345-4109

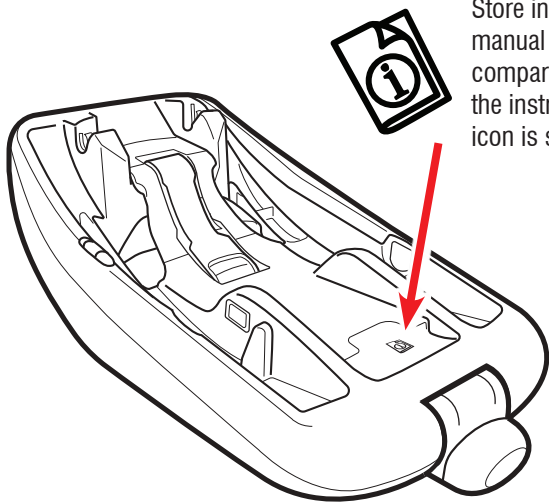

Store instruction
manual in the storage
compartment where
the instruction book
icon is shown.